



**Calhoun: The NPS Institutional Archive**  
**DSpace Repository**

---

Theses and Dissertations

1. Thesis and Dissertation Collection, all items

---

1996-09

# Effectiveness of off-board active decoys against anti-shiping missiles

Tan, Tun-Hou

Monterey, California. Naval Postgraduate School

---

<http://hdl.handle.net/10945/32281>

---

*Downloaded from NPS Archive: Calhoun*



Calhoun is the Naval Postgraduate School's public access digital repository for research materials and institutional publications created by the NPS community. Calhoun is named for Professor of Mathematics Guy K. Calhoun, NPS's first appointed -- and published -- scholarly author.

**Dudley Knox Library / Naval Postgraduate School**  
**411 Dyer Road / 1 University Circle**  
**Monterey, California USA 93943**

<http://www.nps.edu/library>

**NAVAL POSTGRADUATE SCHOOL**  
**Monterey, California**



19970102 005

**THESIS**

**EFFECTIVENESS OF OFF-BOARD ACTIVE DECOYS  
AGAINST ANTI-SHIPING MISSILES**

by

Tan, Tun-Hou

September, 1996

Thesis Advisor:

D. C. Schleher

Approved for public release; distribution is unlimited.

**DTIC QUALITY INSPECTED 1**

# REPORT DOCUMENTATION PAGE

Form Approved OMB No. 0704-0188

Public reporting burden for this collection of information is estimated to average 1 hour per response, including the time for reviewing instruction, searching existing data sources, gathering and maintaining the data needed, and completing and reviewing the collection of information. Send comments regarding this burden estimate or any other aspect of this collection of information, including suggestions for reducing this burden, to Washington Headquarters Services, Directorate for Information Operations and Reports, 1215 Jefferson Davis Highway, Suite 1204, Arlington, VA 22202-4302, and to the Office of Management and Budget, Paperwork Reduction Project (0704-0188) Washington DC 20503.

1. AGENCY USE ONLY (Leave blank)		2. REPORT DATE September 1996	3. REPORT TYPE AND DATES COVERED Master's Thesis	
4. TITLE AND SUBTITLE EFFECTIVENESS OF OFF-BOARD ACTIVE DECOYS AGAINST ANTI-SHIPING MISSILES			5. FUNDING NUMBERS	
6. AUTHOR(S) Tan, Tun-Hou			8. PERFORMING ORGANIZATION REPORT NUMBER	
7. PERFORMING ORGANIZATION NAME(S) AND ADDRESS(ES) Naval Postgraduate School Monterey CA 93943-5000			10. SPONSORING/MONITORING AGENCY REPORT NUMBER	
9. SPONSORING/MONITORING AGENCY NAME(S) AND ADDRESS(ES)			10. SPONSORING/MONITORING AGENCY REPORT NUMBER	
11. SUPPLEMENTARY NOTES The views expressed in this thesis are those of the author and do not reflect the official policy or position of the Department of Defense or the U.S. Government.				
12a. DISTRIBUTION/AVAILABILITY STATEMENT Approved for public release; distribution is unlimited.			12b. DISTRIBUTION CODE	
13. ABSTRACT (maximum 200 words) <p>Radar guided anti-shiping missiles are the primary threat for most modern Navies. The inherent nature of the monopulse radar employed by most anti-shiping missiles makes it highly resistant to active ECM techniques. Decoys are attractive because they provide a source of radiation that can capture the radar seeker and direct the missile away from the ship. However the time and direction of launch are critical parameters which determine the operational success of the decoy.</p> <p>This thesis evaluates the protection provided by active off-board decoys which are deployed by ships during an engagement against a radar guided anti-shiping missile. The research emphasizes launching active decoys. Many of the operational characteristics of the launching decoy are investigated, including direction of launch, timing of launch and the RF characteristics of the decoy.</p>				
14. SUBJECT TERMS Off-board Active Decoys, Anti-shiping Missiles			15. NUMBER OF PAGES 56	
			16. PRICE CODE	
17. SECURITY CLASSIFICATION OF REPORT Unclassified	18. SECURITY CLASSIFICATION OF THIS PAGE Unclassified	19. SECURITY CLASSIFICATION OF ABSTRACT Unclassified	20. LIMITATION OF ABSTRACT UL	

NSN 7540-01-280-5500

Standard Form 298 (Rev. 2-89)  
Prescribed by ANSI Std. Z39-18 298-102



**Approved for public release; distribution is unlimited**

**EFFECTIVENESS OF OFF-BOARD ACTIVE DECOYS AGAINST ANTI-SHIPING MISSILES**

Tan, Tun-Hou  
Lieutenant Commander, Republic of China Navy  
B.S., Republic of China Naval Academy, 1986

Submitted in partial fulfillment  
of the requirements for the degree of

**MASTER OF SCIENCE IN SYSTEMS ENGINEERING**

from the

**NAVAL POSTGRADUATE SCHOOL  
September 1996**

Author:

  
Tan, Tun-Hou

Approved by:

  
D. C. Schleher, Thesis Advisor

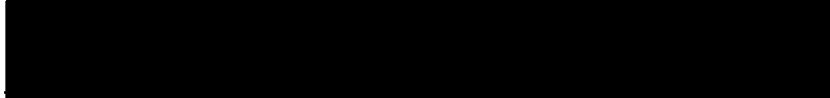
  
David C. Jenn, Second Reader

  
Frederic H. Levien, Chairman  
Electronic Warfare Academic Group



## ABSTRACT

Radar guided anti-shiping missiles are the primary threat for most modern Navies. The inherent nature of the monopulse radar employed by most anti-shiping missiles makes it highly resistant to active ECM techniques. Decoys are attractive because they provide a source of radiation that can capture the radar seeker and direct the missile away from the ship. However the time and direction of launch are critical parameters which determine the operational success of the decoy.

This thesis evaluates the protection provided by active off-board decoys which are deployed by ships during an engagement against a radar guided anti-shiping missile. The research emphasizes launching active decoys. Many of the operational characteristics of the launching decoy are investigated, including direction of launch, timing of launch and the RF characteristics of the decoy.





## TABLE OF CONTENTS

I.	INTRODUCTION .....	1
II.	GENERAL SCENARIO .....	3
	A. ANTI-SHIPING MISSILES ATTACK PROCEDURES .....	3
	1. Target Acquisition .....	3
	2. Target Tracking .....	4
	3. Midcourse Guidance .....	5
	4. Terminal Guidance .....	5
	B. ACTIVE DECOY DEPLOYMENT PROCEDURES .....	7
	1. Countertargeting Decoys .....	7
	2. Distraction/Dilution Decoys .....	8
	3. Seduction Decoys .....	8
III.	STATEMENT OF THE PROBLEM .....	11
	A. THE SCENARIO .....	11
	B. THE PROBLEMS .....	11
IV.	THE MODELS .....	13
	A. THE SHIP MODEL .....	13
	1. Radar Cross Section .....	13
	a. <i>Average RCS Computation</i> .....	13
	b. <i>RCS as a Function of Viewing Angle</i> .....	14
	2. Kill Distance .....	15
	B. THE DECOY MODEL .....	16
	C. THE MISSILE MODEL .....	22
	D. THE SEEKER MODEL .....	22
V.	DISCUSSION .....	25
	A. DECOY DEPLOYMENT ANGLE .....	25
	B. DECOY DEPLOYMENT DISTANCE .....	32
	C. DECOY GAIN AND POWER REQUIREMENT .....	35
	1. Decoy Gain Requirement .....	35
	2. Decoy Power Requirement .....	36
VI.	CONCLUSIONS .....	39
	LIST OF REFERENCES .....	41
	INITIAL DISTRIBUTION LIST .....	43



## LIST OF FIGURES

1. Target Acquisition .....	3
2. Target Tracking .....	4
3. Midcourse Guidance .....	5
4. Terminal Guidance .....	6
5. Target Lock-on .....	6
6. Countertargeting Decoys .....	8
7. Seduction Decoys .....	9
8. The General Scenario .....	10
9. RCS of a Naval Ship Polar Plot .....	14
10. RCS of a Frigate Ship Polar Plot .....	15
11. Typical Repeater Diagram .....	16
12. Jam-to-signal Ratio of a Constant Gain System .....	18
13. Jam-to-signal Ratio of a Saturated Case .....	20
14. Monopulse Radar Antenna Pattern .....	24
15. Amplitude-comparison Monopulse Pattern .....	24
16. Protection Envelope of Decoys for a Missile from 345 Degrees .....	26
17. Protection Envelope of Decoy for a Missile from the Bow .....	28
18. Protection Envelope of Decoy for a Missile from the Starboard side .....	29
19. Protection Envelope of Decoy for a Missile from the Stern .....	30
20. Protection Envelope of Decoy for a Missile from the Port Side .....	31
21. Effect of Different Decoy Deployment Distance (Polar) .....	32
22. Effect of Different Decoy Deployment Distance (Cartesian) .....	33
23. Seeker's Resolution Cell .....	34
24. Decoy Power versus Ship Echo at Seeker's Receiver .....	37



## LIST OF TABLES

1. Typical Frigate Features .....	13
2. Parameters of the Missile Model .....	22
3. Parameters of the Seeker Model .....	23
4. Decoy Deployment Angle versus Miss Distance with a 345 degrees Attack Angle. .	26
5. Optimized Decoy Deployment Angle .....	27



## I. INTRODUCTION

The modern, sophisticated anti-shiping missile (ASM) is a major threat to surface warships. To provide protection against ASM, several ECM techniques were developed and successfully deployed. However, the competition between attackers and defenders never has an end. Weapon systems and defense systems are inciting each other to a more elevated level. To ensure the effectiveness of ASM against conventional ECM techniques, monopulse tracking, frequency and amplitude modulations, home-on-jam mode, frequency agility/diversity and chaff discrimination are all used together in constructing ASM seekers. This makes conventional ECM techniques less effective.

This problem can be solved by integrating off-board active decoys into the ECM family. The decoys provide a high fidelity return signal to the enemy radar, at the proper power level, frequency, time, and angle, and with all associated modulations. To any ECCM technique listed above, an active off-board decoy appears to be a real and more attractive target.

There are several ways to deploy off-board active decoys to protect ships. Each method has its trade-off. Decoys can be deployed by helicopter, towed by ship, launched by rocket then kept in air by parachute. This thesis examines the use of a shipboard rocket-launched active electronic buoy. The buoy is cheaper in operation than a helicopter deployed decoy, it can operate longer than a parachute decoy, and provides better flexibility for the ship to maneuver than a towed decoy. For these reasons, it is a preferred way to deploy a decoy.

There are several factors which should be considered to ensure the effectiveness of the rocket launched active buoy decoy. These include deployment angle, deployment range and the proper power gain. This thesis uses MATLAB to simulate an anti-shiping missile attack scenario, and determine the best way to use an active decoy to protect the ship.





## II. GENERAL SCENARIO

### A. ANTI-SHIPPING MISSILES ATTACK PROCEDURES

A typical anti-shiping missile attack procedure includes target acquisition, target tracking, midcourse guidance, and terminal guidance.

#### 1. Target Acquisition

Figure 1 demonstrates target acquisition. This is done by the platform of the missile or by another sensor, then the data is provided to the missile platform through a data link or other means of communication. At this stage, the defending ship might or might not be able to pick up any sign of the threat. This is because the frequencies and PRFs of surface search radars are similar to that of the navigation radars used by cargo ships. This radar information does not always provide significant threat information to the defending ship. If the missile is equipped with a data link or other advance communication systems, it is even more difficult for the defending ship to receive early warning by intercepting the transmitted data.

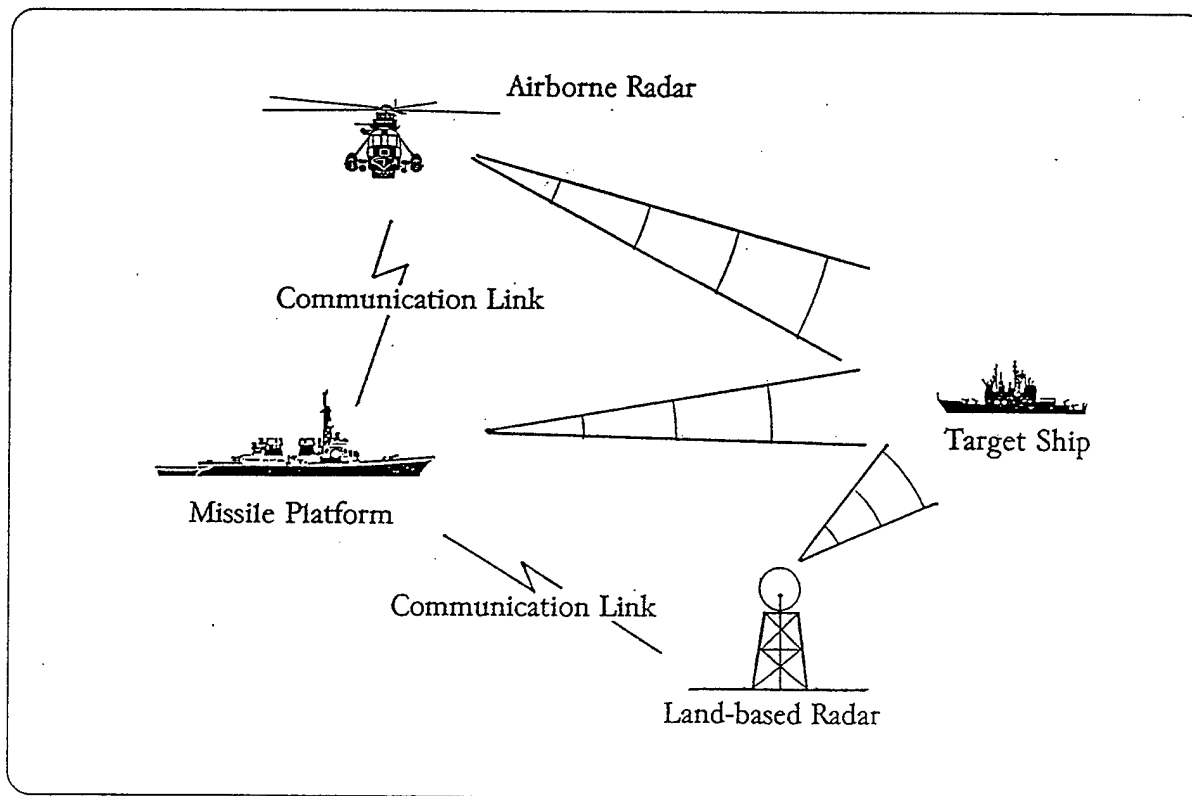

Figure 1. Target Acquisition

## 2. Target Tracking

Similar to the target acquisition stage, target tracking can be performed by other sensor platforms and data linked to the missile launching vehicle or received by the missile vehicle itself. Generally, the link method is preferred by the attacker side, because it can extend the attack range over the horizon. A typical target tracking scenario is shown in Figure 2. The helicopter performs as a remote sensor, it provides data on the target ship to the missile launching vehicle. The attack then can be carried out by the missile platform even without seeing the targets. In this case, even though the ESM system onboard the defending ship might be able to intercept the helicopter's radar signal, it does not necessarily imply the missile will come from the same direction. Also, the missile can be launched beyond the line of sight, so that the shipboard radar will not be able to detect the presence of the missile vehicle when the missile is launched. So neither the ESM system nor the radar can discernibly provide early warning.

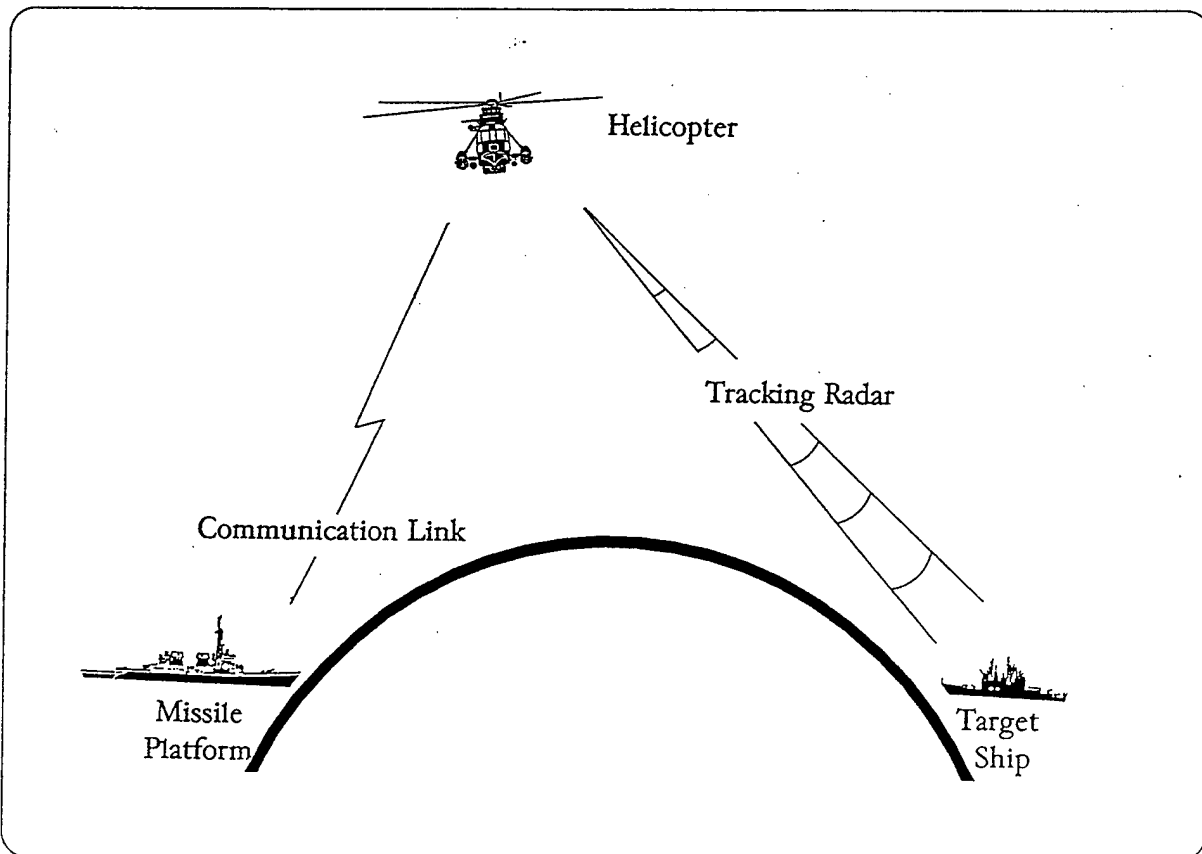

Figure 2. Target Tracking

### 3. Midcourse Guidance

The third stage is shown in Figure 3. At this stage the missile is launched, and its midcourse guidance is done by autopilot. At this stage neither the missile launching vehicle nor missile transmits a signal. The defending ship will not be able to intercept any RF signal with their ESM system. When the missile comes into the defending ship's radar detection range, the ship may be able to detect the rapidly approaching target. However, most anti-shipping missiles are sea skimming and at such low attitudes may not be seen before they are very close to the ship.

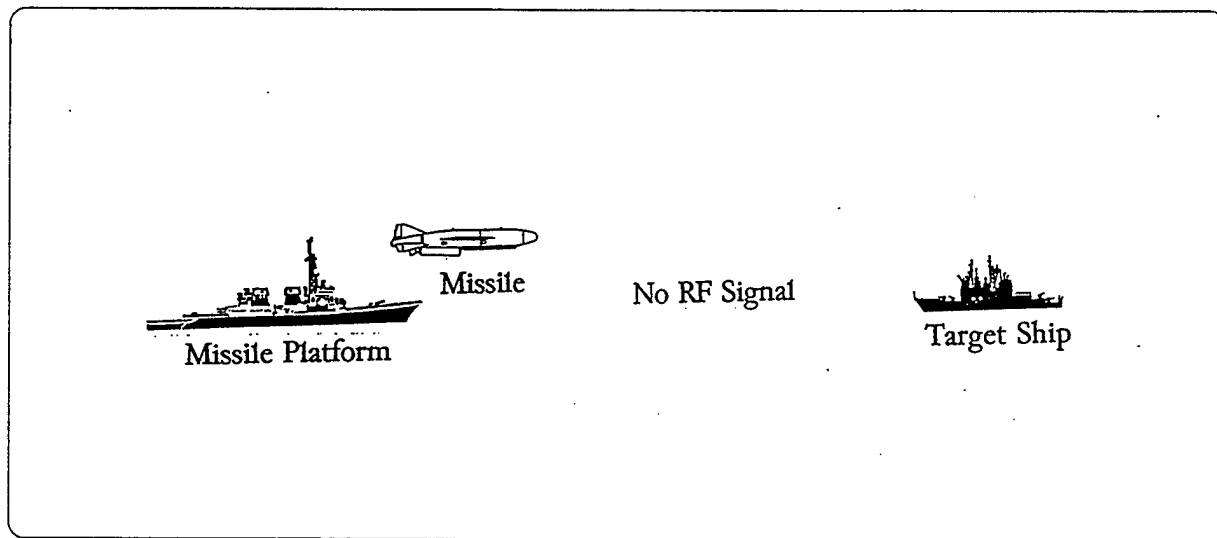

Figure 3. Midcourse Guidance

### 4. Terminal Guidance

The next stage of the missile engagement is shown in Figure 4. This stage is initiated when the missile turns its seeker on and starts to search for the target ship within a certain range of angle. This stage usually takes place when the missile to target distance is between 4 to 12 km. The range depends upon how accurately the autopilot program can guide the missile to the right location and where the seeker may first see the target ship after the seeker starts to search. Also, because the seeker's transmission provides a clear threat signature to the target ship, the later the seeker turns on, the shorter reaction time available for the target ship. There are several types of

seekers; RF radar, infrared or a combination of the two. In this thesis we concentrate on a monopulse radar seeker as the model since this is the most significant threat.

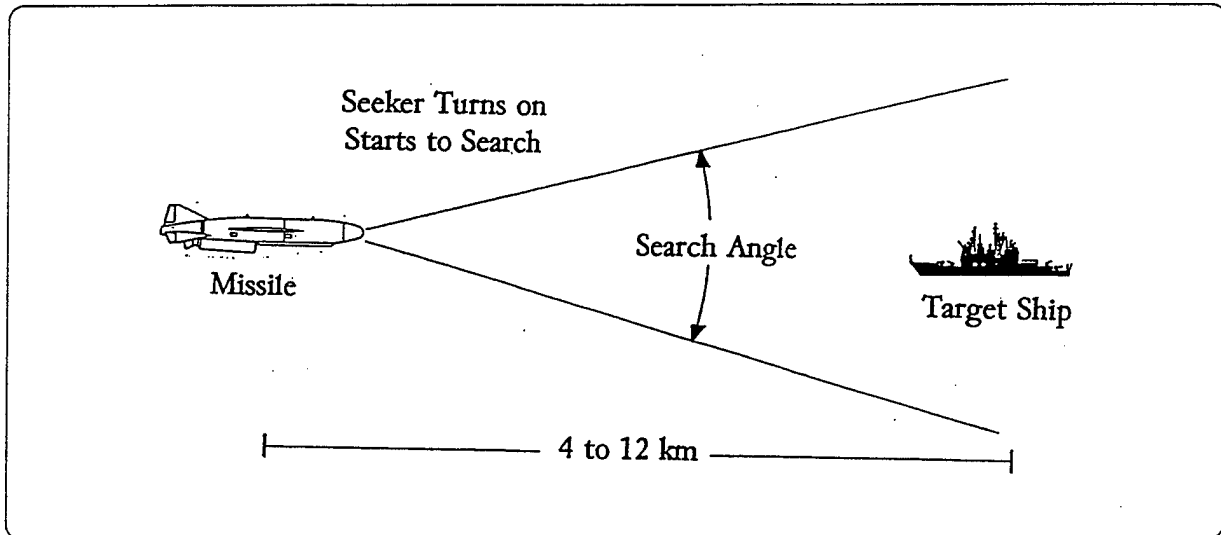

Figure 4. Terminal Guidance

After the seeker finds the target, it will change to a lock-on tracking mode. Lock-on is shown in Figure 5. At this point, the target ship will receive a steady RF signal. If neither 'hard kill' nor 'soft kill' is used by the defense ship, the missile seeker will remain locked onto the ship until it intercepts the target.

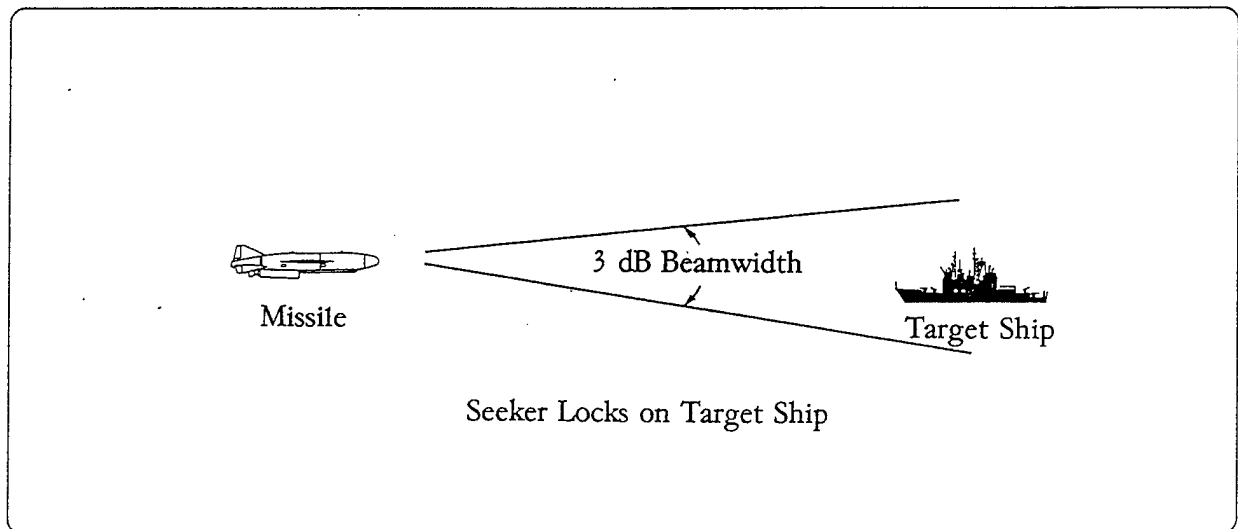

Figure 5. Target Lock-on

## **B. ACTIVE DECOY DEPLOYMENT PROCEDURES**

During the entire missile attack procedure, the defending side has some chances to interrupt the missile engagement procedures. The following is a description of how active decoys may possibly be used to protect the ship from attack.

### **1. Countertargeting Decoys**

This could be employed at stage 1 when the enemy is trying to acquire the target ship's information. If at this time the ship can pick up the signal and verify its threat against a good databank, it may launch an active decoy to mislead the attack side. This is shown in Figure 6. The assumption made here, is that the defense ship has the threat signal bearing from its ESM system sooner than the missile vehicle can capture the target ship with its radar. Using the threat bearing, the defense ship can launch active decoys, usually along the threat bearing. Since it is assumed that the ESM has a longer detection range than the attackers radar, immediately after decoy deployment, the missile vehicle does not see either the ship or the decoy. As time passes, the missile vehicle will first see the decoys, and then the ship. The best result for the defender is for the missile vehicle to interpret the decoys as real targets and begin to maneuver for the best tactical position and then to attack. While the missile vehicle is maneuvering, the intended target, the ship, will be given time to either escape or take advantages of the missile vehicles' position change to engage the missile.

However, this ideal result is not likely in the real world. Using decoys to deceive a search radar has an objective to deceive the radar's operators. Unlike a seekers' radar system, processing any incoming signals in a fixed routine, an operator can reason, check the speed and course of the target, verify his radar information against other sources and discriminate an echo from a decoy. Yet, one cannot say the defense is a failure if the operator recognizes that the decoy is not the real target. The decoy can still provide something valuable to the targeted ship, that is time, which is very important on the battlefield.

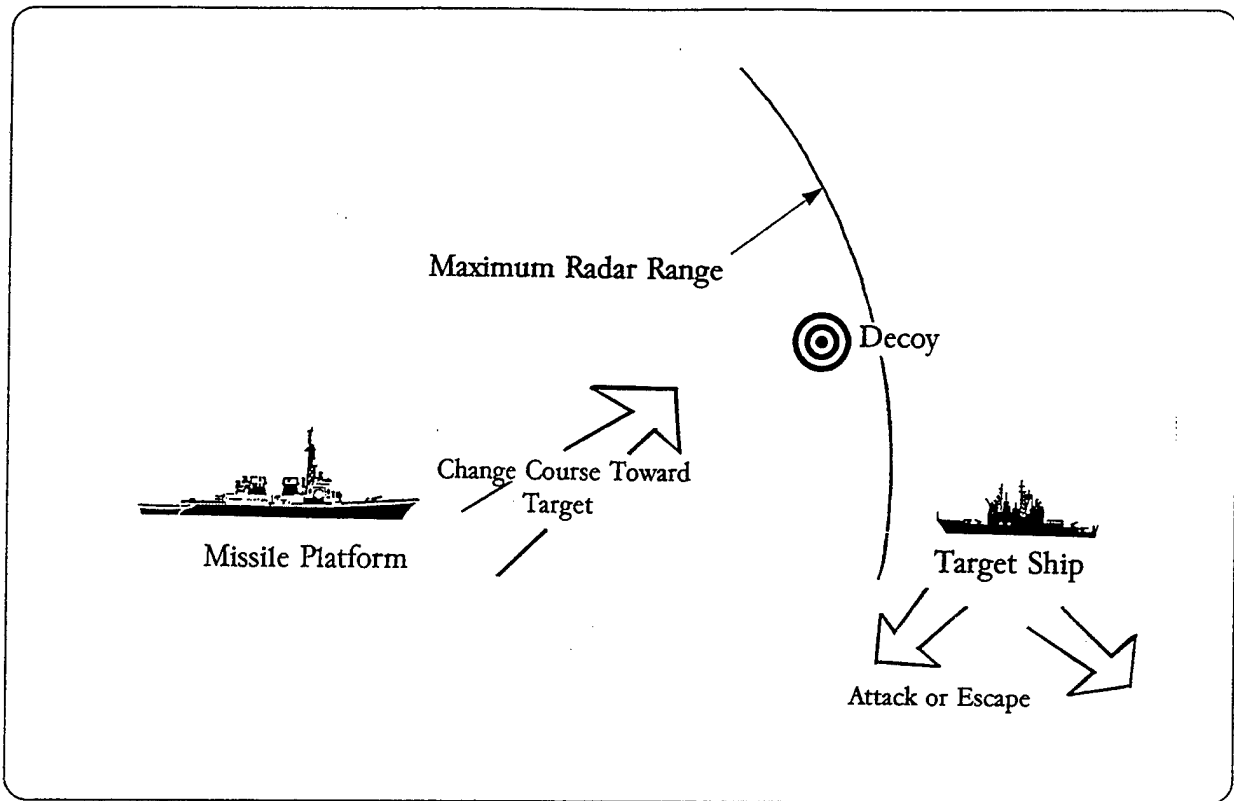

Figure 6. Countertargeting Decoys

## 2. Distraction/Dilution Decoys

The next role that the decoys can play is distraction/dilution. This is performed before the missile vehicle begins target tracking with its fire control radar. By deploying several decoys around the real target ship, the defender makes it difficult for the missile vehicle to track the correct target. Again this problem can be overcome by an experienced operator, but the defending ship will gain some time to prepare its anti-missile defense.

## 3. Seduction Decoys

The most important role that decoys can play in anti-missile defense is seduction. Seduction can be performed in two cases. The first case is if the defending ship can maintain a good track of the incoming missile with its radar, allowing the missile turn-on-time to be estimated. The decoy should be deployed before the missile turns on its seeker. When the seeker turns on and starts its search, it will lock on the stronger target echo, which if correctly positioned, is the decoy.

If the missile is not tracked by the defending shipboard radar, or if the defender is totally unaware of the threat of the missile before its seeker turns on, then the decoy can still contribute to the protection of the ship. When the seeker locks on to the ship, it provides a very steady RF signal to the target ship. Even through the steady signal means the ship is being tracked, a decoy can be launched "properly" at this point and may still lure the missile away from the ship. Figure 7 shows the use of a seduction decoy. The critical question is: what is the definition of "properly," or how to deploy the decoy in order to provide protection for the ship? This is the question that is studied in this thesis.

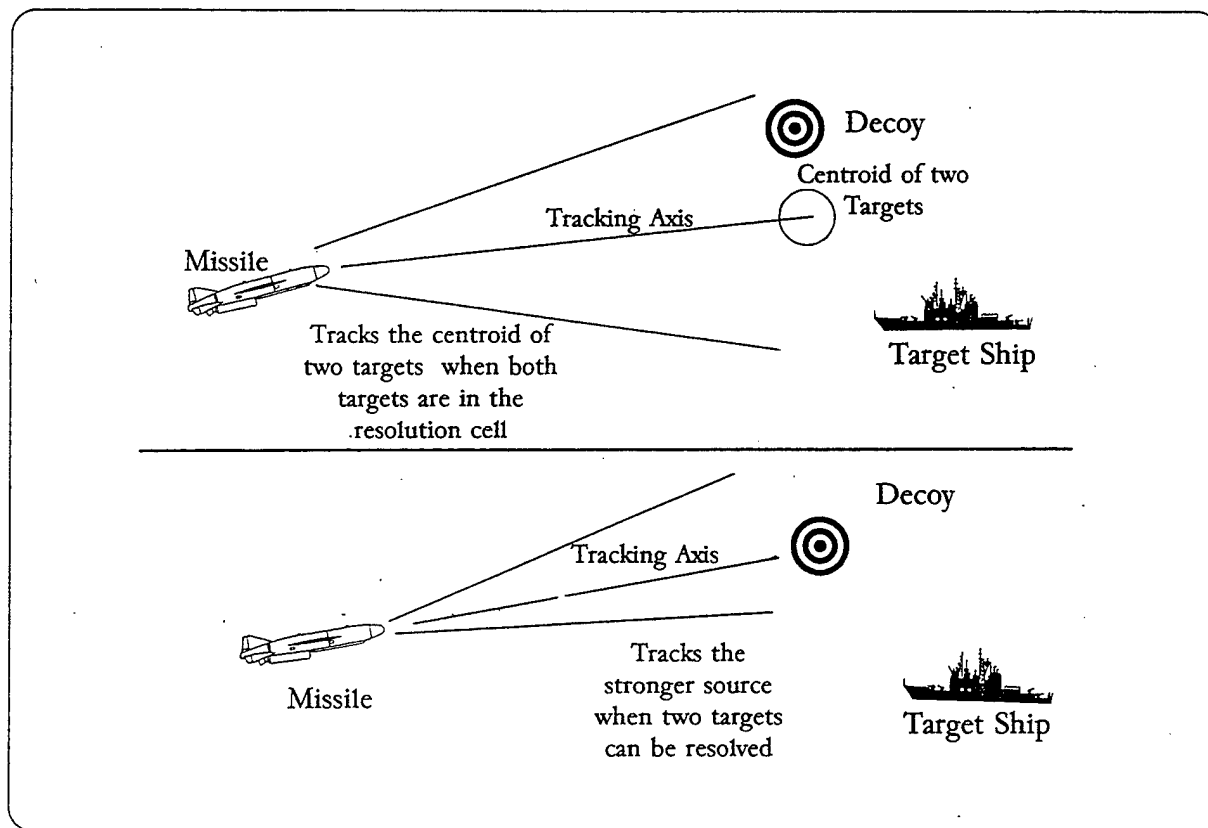

Figure 7. Seduction Decoy





### III. STATEMENT OF THE PROBLEM

#### A. THE SCENARIO

The scenario is shown in Figure 8. Usually the relative bearing is the preferred axis in anti-missile defense, so the heading of the ship is used as the reference axis.  $\theta_M$  is the missile attack angle,  $\theta_D$  is the decoy angle,  $R_M$  is the missile distance at which the seeker turns on, and  $R_D$  is the initial decoy distance from the ship.

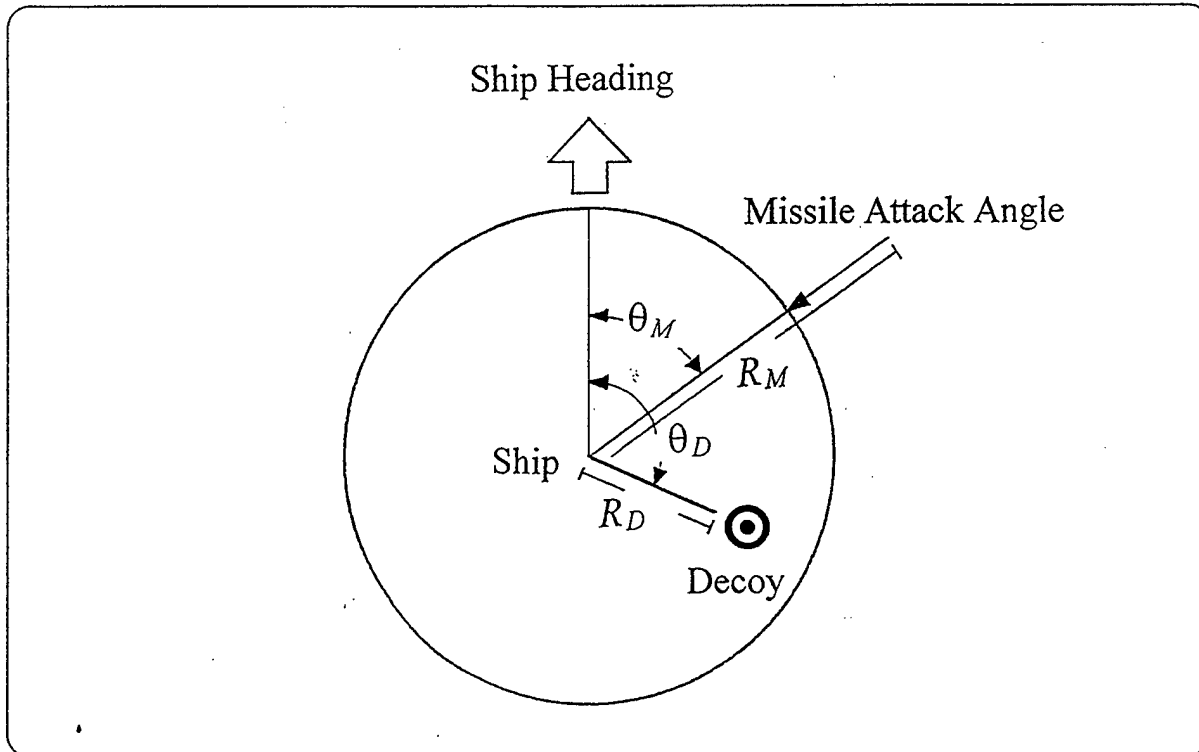

Figure 8. The General Scenario

#### B. THE PROBLEMS

For the decoy to provide the best protection, it should be as far away from the defending ship as possible, so that the chance of the seeker locking back on the defender is small. But the decoy should not be so far away that it exceeds the seeker's beam width (i.e., 3dB beam angle). This would be out of sight to the seeker. So the problem is to find the deployment angle and deployment distance that is an optimized result of distance from the ship and within the 3 dB beam width of the seeker. Besides the best angle and range of the decoy deployment, the decoy

must be a more attractive target than the targeted ship. This study also addresses how much gain a repeater type active decoy must have to ensure its effectiveness.

#### IV. THE MODELS

The purpose of this simulation model is to study the anti-shiping missile's behavior with the target ship and decoys both present in the same resolution cell. Basically the missile seeker always tends toward the center-of-gravity of the target sources within its acceptance beam. Thus if the decoy is stronger than the ship the seeker will tend to point toward the decoy. The key point for investigation in this simulation, is how does the decoy power compete with the target ship echo power throughout the entire tracking and lock on procedure of the seeker. To make this point clear, the following models are programmed.

##### A. THE SHIP MODEL

The ship model we used in the simulation is a frigate, its basic features are shown in Table 1. The maneuver of the ship at the time it detects the seeker signal is assumed to be an increase of speed to its maximum, but without a course change.

Displacement, tons	2,750 light; 4,105 full load
Dimensions, metres	138.1 x 13.7 x 4.5
Speed	29 kts

Table 1. Typical Frigate Features. After Ref. [1:p.696]

There are two things that must be discussed about the target ship: radar cross section (RCS) and the killing distance.

##### 1. Radar Cross Section

The RCS of the ship is important in computing the echo power of the ship as received by the seeker. Echo power varies significantly with target orientation at high frequency. This is because the size of the ship is much greater than wavelength of the seeker, so the incident wavelength can easily resolve target details. [Ref. 2:p.11.1] In this simulation viewing angle dependence must be taken into account. This is done in the following way.

##### a. Average RCS Computation

The average RCS of the frigate is computed using an empirical formula for the RCS of a naval ship [Ref. 2:p.11.17]

$$\sigma = 52f_d^{\frac{1}{2}}D^{\frac{3}{2}}, \quad (1)$$

where  $f_d$  is the radar frequency in megahertz and  $D$  is the full-load displacement of the vessel in kilotons.

**b. RCS as a Function of Viewing Angle**

Figure 9 shows the RCS of the naval ship at different viewing angles. The data was collected by a shore-based radar instrumentation complex as the ship steamed in a large circle on Chesapeake bay. [Ref. 2:p.11.19]

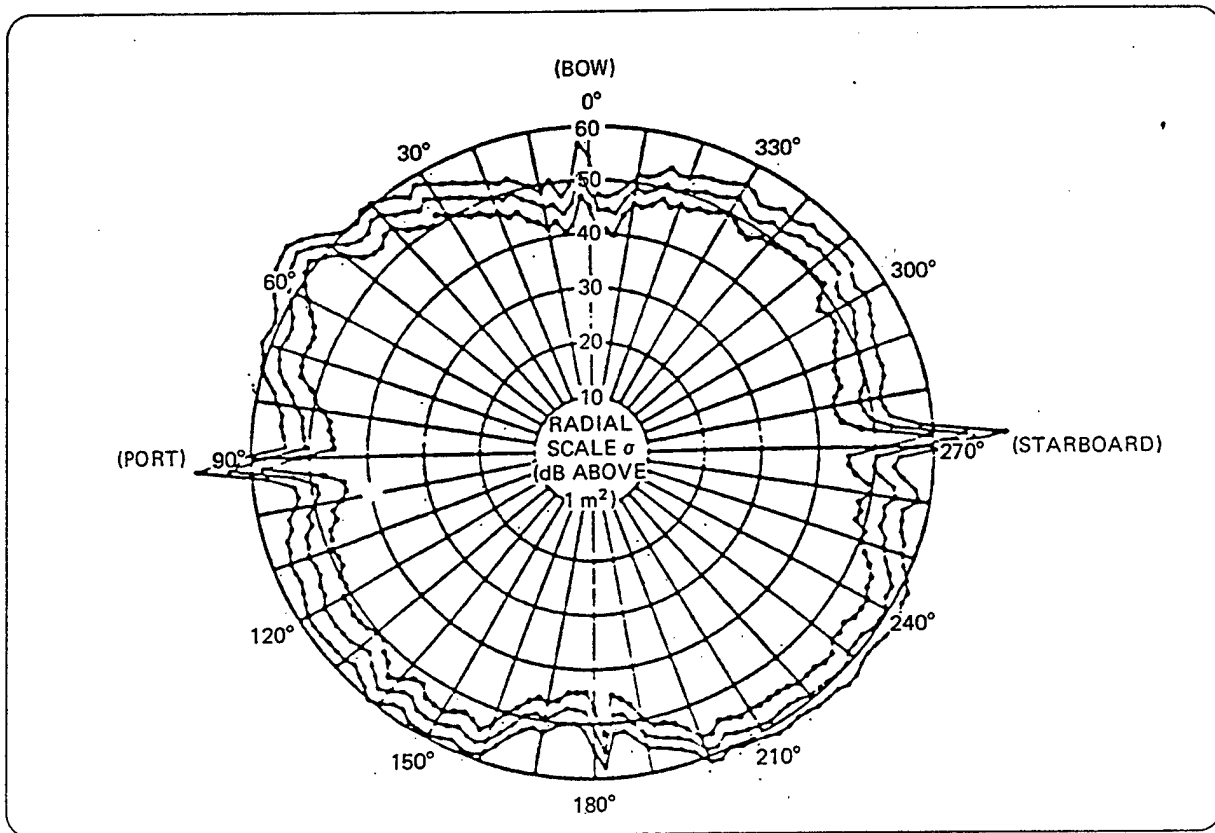

Figure 9. RCS of a Naval Ship Polar Plot. From Ref.[2:p11.19]

The average result obtained from (1) was used to scale the RCS in Figures 9 to correspond to that of a Frigate, as shown in Figure 10.

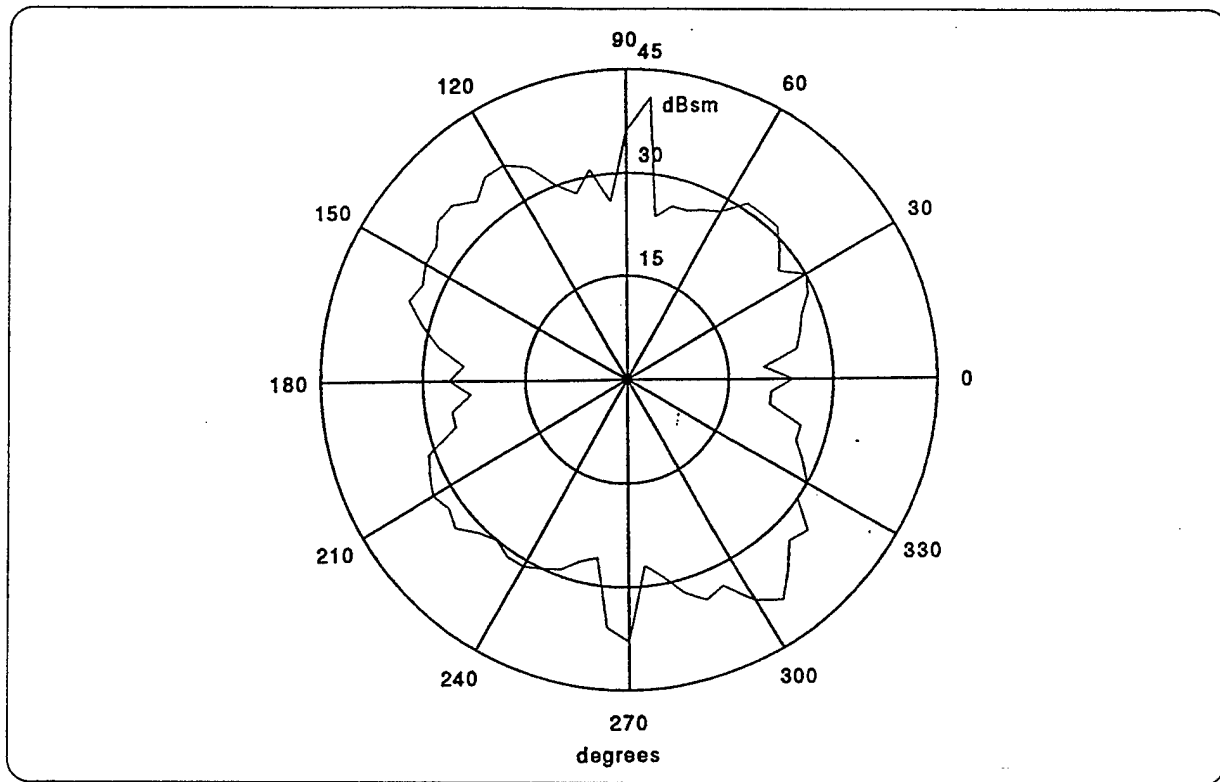

Figure 10. RCS of a Frigate Ship Polar Plot

## 2. Kill Distance

The ultimate goal of the active decoy is to lure the missile as far away from the ship as is possible. When evaluating the protection provided by different decoys' deployment range/angles, the minimum distance is computed between the missile and the center of the target ship.

However, if only minimum distance is considered, it cannot be determined if the missile will hit the target. This is because when computing the minimum distance, the center of the ship was used as a reference point. The ship's physical length must also be taken into account when deciding if the ship is within kill distance ( $K_S$ ). This is given by

$$K_S = \cos(\theta_M) \cdot L_S, \quad (2)$$

where  $L_S$  is the length of the ship. If  $K_S < W_S$  where  $W_S$  is ship's width, that is if it is a bow or stern approach, then the kill distance becomes the width of the ship.

## B. THE DECOY MODEL

The decoy model is basically a repeater, The general repeater diagram is shown in Figure 11. For the repeater, the transmitted signal is the true replica of the signal intercepted.

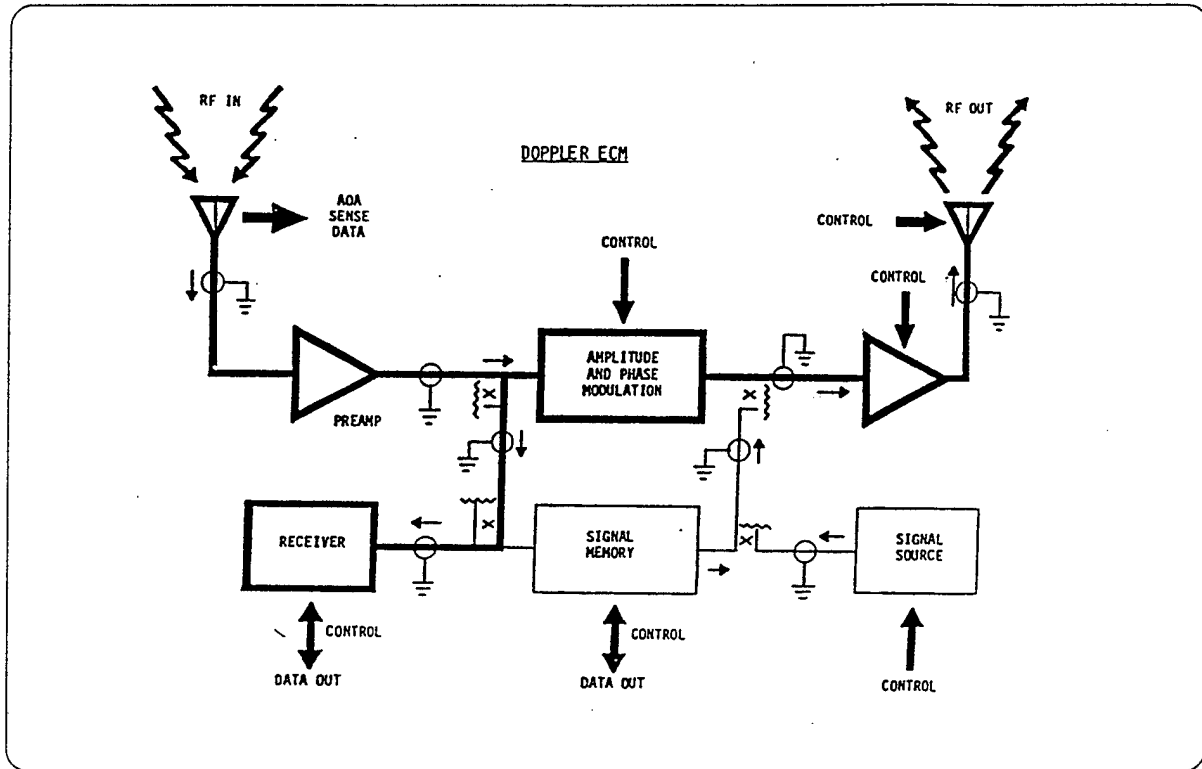

Figure 11. Typical Repeater Diagram From Ref. [3:p.39]

The transmitted radar signal received at the repeater jammer is given by: [Ref. 4:p423]

$$P_{JR} = \frac{P_T G_T G_{DR} \lambda^2}{(4\pi R)^2 L_P}, \quad (3)$$

where

$P_T$  = Radar Transmitted Power,

$G_T$  = Radar Transmitter Antenna Power Gain,

$G_{DR}$  = Repeater Receiver Antenna Power Gain,

$\lambda$  = Radar's Wavelength,

$R$  = Range Between Radar and Repeater,

$L_P$  = Polarization Loss.

There is an important component that must be examined: Polarization. Polarization loss ( $L_P$ ) is the loss that occurs when the jammer antenna and the radar antenna are operating with different polarization. This is a common occurrence because jammers are generally circularly polarized or 45-degree slant polarized to accommodate a variety of victim radars.[Ref. 4:p.419]

The signal from the receiving antenna is passed through the amplitude and phase modulation unit, which provides the appropriate modulation for the signal as it passes through the output amplifier and the transmitting antenna towards the victim radar. [Ref. 3:p38] The output of the repeater transmitter is given as

$$P_J = \frac{P_T G_T G_{DR} G_{DT} G_D \lambda^2}{(4\pi R)^2 L_P}, \quad (4)$$

where

$G_{DT}$  = Repeater Transmitter Antenna Power Gain,

$G_D$  = Repeater Amplifier Gain.

The repeated jammer signal at the radar terminals ( $P_{RJ}$ ) is then given by:

$$P_{RJ} = \frac{P_T G_T^2 G_{DR} G_{DT} G_D \lambda^4}{(4\pi R)^4 L_P^2}. \quad (5)$$

In this type of operation, the output of the transmitter is directed at the intercepted signal. This system is referred to as a constant gain system. The output of the transmitter is not necessarily the maximum output of the transmitter, but depends on the level of the intercepted signal multiplied by the gain of the amplifying system [Ref. 3:p38]

Since the target ship return signal to the radar is given by:

$$P_R = \frac{P_T G_T^2 \sigma \lambda^2}{(4\pi)^3 R^4}, \quad (6)$$

the jam-to-signal ratio is then given by combining Equations (5) and (6)

$$\frac{J}{S} = \frac{G_{DR}G_{DT}G_D\lambda^2}{4\pi\sigma L_P^2} \quad (7)$$

As we can see, the jam-to-signal ratio is independent of range. To illustrate this fact, the following data have been used to apply Equations (5) and (6):

$P_T$	$G_T$	$\lambda$	$L_P$	$\sigma$	$G_{DR}$	$G_{DT}$	$G_D$	$P_D$
200 kw	35 dB	0.003 m	3 dB	$50m^2$	10 dB	10 dB	35 dB	1 kw

The result is shown in Figure 12. As the figure shows, the jam-to-signal ratio is equal to 7.42 dB, independent of range.

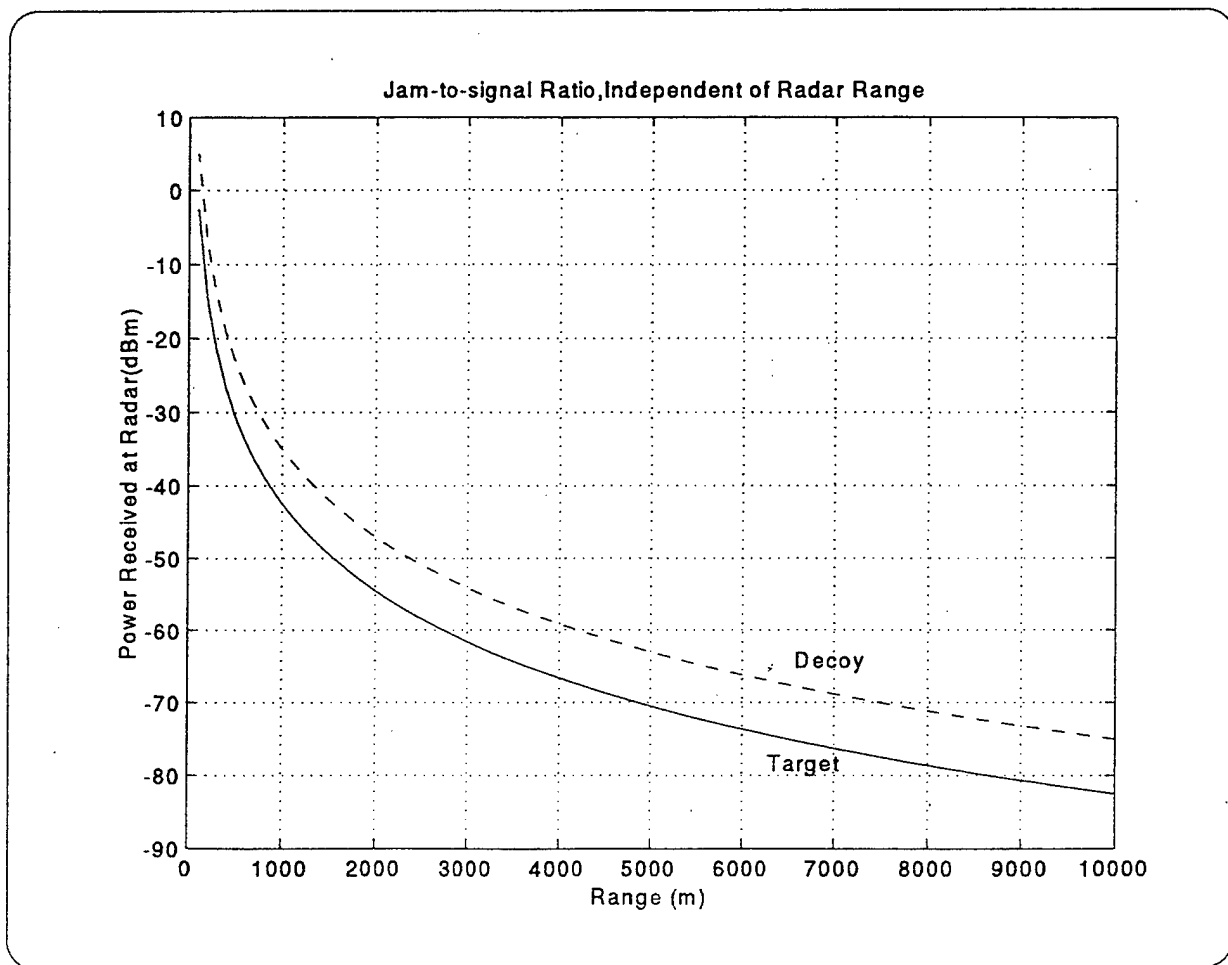

Figure 12. Jam-to-signal Ratio of a Constant Gain System



In reality, the power of the transmitter systems is not unlimited; the gain of the system eventually will drive the level of signal to the point that demands maximum power out of the transmitter. Having reached this power level, any further increase in intercepted signal will result in the same maximum power level out of the transmitter. At ranges less than that point, the system operates as a constant power system. [Ref.3:p.43] Having a constant power output repeater, the transmitted power received by the radar is then given by

$$P_{RJ} = \frac{P_{\max} G_T \lambda^2}{(4\pi R)^2 L_P}, \quad (8)$$

where  $P_{\max}$  is the maximum repeater power output.

Combining Equations (6) and (8) we can get the jam-to-signal ratio after the repeater is saturated:

$$\frac{J}{S} = \frac{4\pi R^2 P_{\max}}{P_T G_T \sigma L_P}. \quad (9)$$

Figure 13 shows the jamming and signal power for saturation. The decoy saturates at  $R= 3700$  m. At this point, the repeater changes to a constant power system instead of a constant gain system. At  $R= 1600$  m, the jam-to-signal reduces to 1. This is the burn-through range. Beyond the burn-through range the jammer power is less than the target return echo and will not be effective.

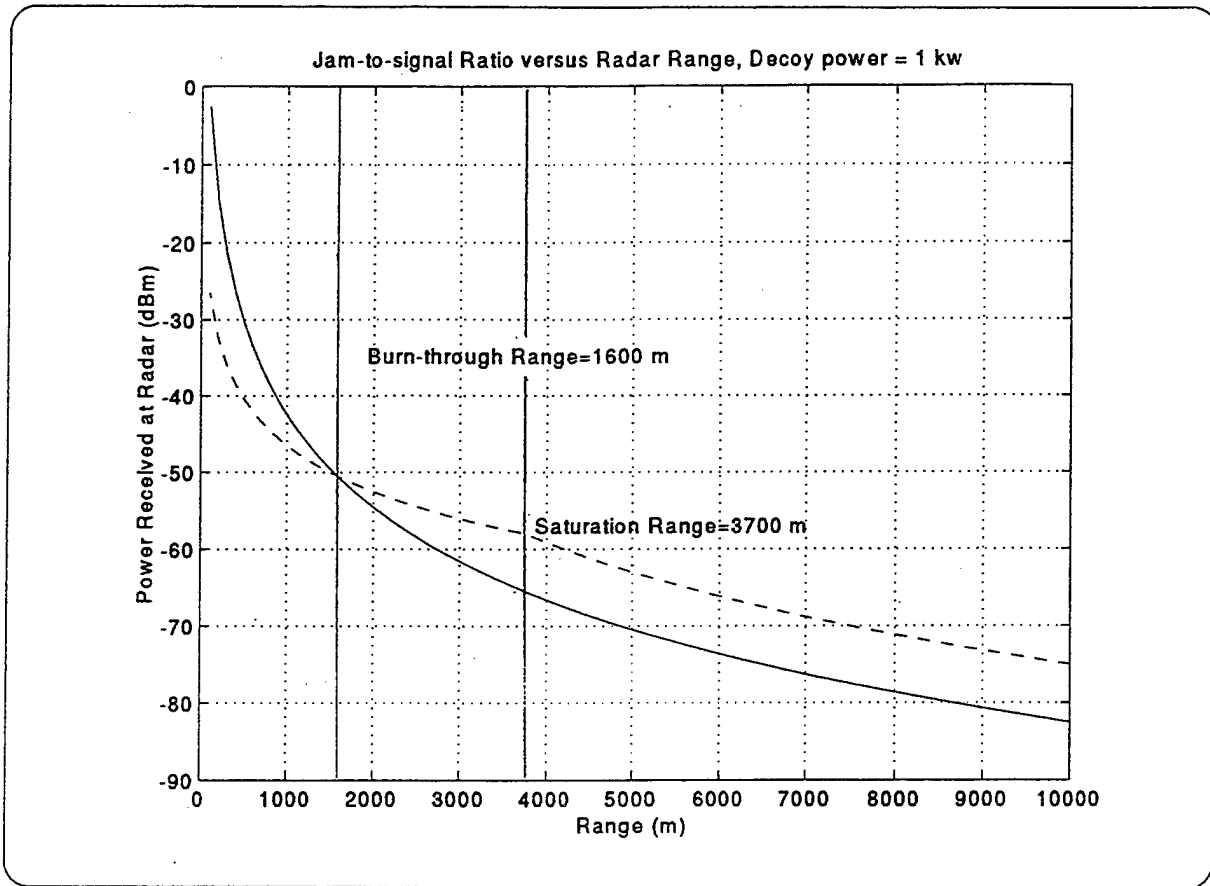

Figure 13. Jam-to-signal Ratio of a Constant Power System

The above discussion was a description of a typical repeater. In the model used in this study, the description must be modified. First, the repeater used in the thesis is supposed to be able to respond to any threat direction, which requires an omnidirectional antenna. Thus, the decoy receiving and transmitting antenna gain can be made equal to one and hence can be omitted from the model. Second, the repeater used in this study is an off-board device, the distance and angle between ship and decoy will change as the ship starts its maneuver. This ship movement implies the distance between missile and ship is different from the distance between the missile and the decoy. Taking all this into account, Equations (3) through (9) are rewritten as follows.

The transmitted radar signal received at the jammer,

$$P_{JR} = \frac{P_T G_T \lambda^2}{(4\pi R_D)^2 L_p}, \quad (10)$$

where  $R_D$  is the distance between the radar and the decoy. Notice that  $G_{DR}$  has been removed because the decoy's antenna is omnidirectional.

The output of the repeater transmitter before the repeater saturates is

$$P_J = \frac{P_T G_T G_D \lambda^2}{(4\pi R_D)^2 L_P}, \quad (11)$$

where both  $G_{DR}$  and  $G_{DT}$  are equal to one.

The repeated jammer signal at the radar terminals before the repeater saturates is then:

$$P_{RJ} = \frac{P_T G_T^2 G_D \lambda^4}{(4\pi R_D)^4 L_P^2}. \quad (12)$$

Now using Equations (5) and (11) we have the jam-to-signal ratio for the off-board decoy case,

$$\frac{J}{S} = \frac{G_D \lambda^2 R_S^4}{4\pi \sigma L_P^2 R_D^4}. \quad (13)$$

Notice the jam-to-signal ratio is no longer range independent. When the missile is far away from both the ship and the decoy,  $\frac{R_S^4}{R_D^4}$  is approximately equal to 1, This does not have much effect on the overall jam-to-signal ratio. As the missile approaches the target area,  $\frac{R_S^4}{R_D^4}$  will contribute more and more to the jam-to-signal ratio.

Similarly, taking the range difference into account, the jam-to-signal ratio after the decoy saturates is:

$$\frac{J}{S} = \frac{P_{\max} 4\pi R_S^4}{P_T G_T R_D^2 \sigma L_P}, \quad (14)$$

where a new component  $\frac{R_S^4}{R_D^2}$  has been added.

### C. THE MISSILE MODEL

The missile model used in this thesis is the Fei-Lung-1 anti-shiping missile, its basic features are summarized in Table 2.

Mission	Surface-to Surface
Length	7.3 m
Diameter	~ 78 cm
Span	~ 2.8 m
Weight	~ 2300 kg
Range, Max.	100 km
Altitude	Cruise at 30 m, Attack at 15 m
Warhead	500 kg
Speed	Mach 0.9
Fuzing	Deployed contact fuzing
Midcourse guidance	programmed autopilot control
Terminal guidance	Active monopulse radar or Passive IR homing

Table 2. Parameters of the Missile Model. After Ref. [5:p70]

### D. THE SEEKER MODEL

Since the parameters of Fei-Lung-1 missile seeker are classified, this study uses a typical magnetron produced by CelsiusTech Electronics as the seeker model. The data for this magnetron is shown in Table 3.

Center frequency	9250 MHz
Agile bandwidth	400 MHz
Peak power output	100 kw
PRF	3600 pps
Duty factor	0.001 1/sec
Pulse width	0.3 usec

Table 3. Parameters of The Seeker Model

The gain of the antenna is estimated by:

$$G = \frac{4\pi A_r}{\lambda^2} \cdot \eta, \quad (15)$$

where

$A_r$  = Seeker Antenna Aperture,

$\eta$  = Antenna Efficiency Factor.

The Beamwidth of the seeker is estimated by:

$$B_w = 60 \frac{\lambda}{D}, \quad (16)$$

where

$D$  = diameter of the antenna.

The seeker model chosen is an amplitude comparison monopulse radar. Since the azimuth axis is the main guidance component of the missile, the discussion is limited to two-dimensional tracking (i.e., azimuth and range) only. Thus, instead of the conventional three channel signal for the typical monopulse radar, a two channel signal pair is used.

Figure 14 shows a monopulse radar antenna pattern, channel A and B are both complex numbers and can be expressed as  $A = X_A + jY_A$  and  $B = X_B + jY_B$  where  $X$  is the real part and  $Y$  is the complex part. The monopulse radar locks its tracking axis onto the target by nullifying the tracking error, which is given by

$$\varepsilon = \text{Real} \left( \frac{A-B}{A+B} \right). \quad (17)$$

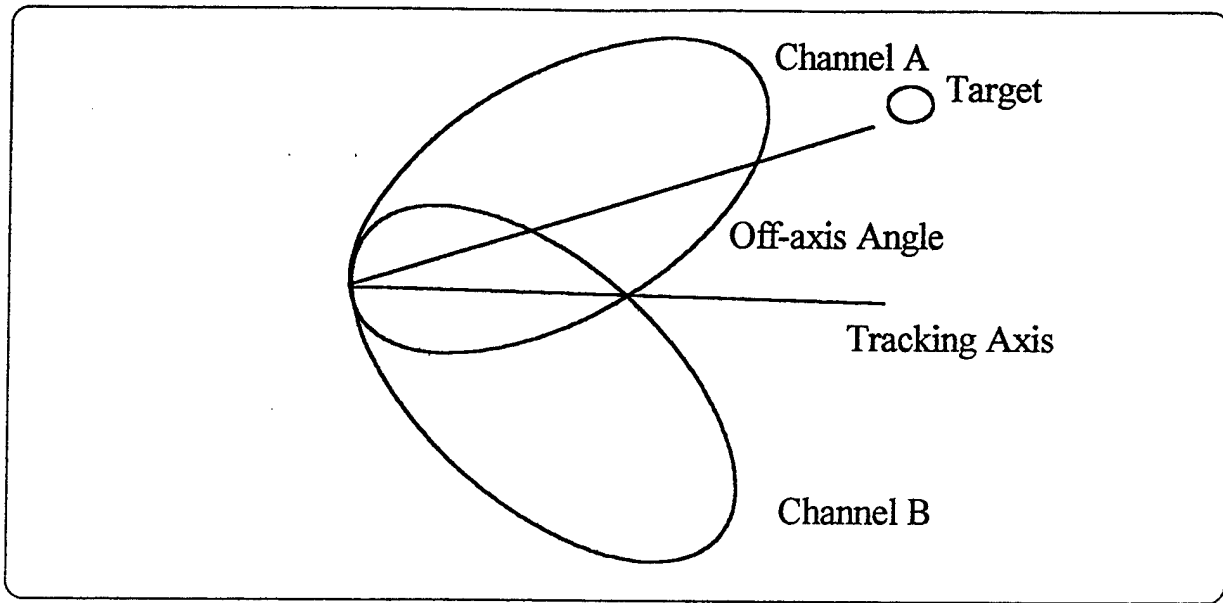

Figure 14. Monopulse Radar Antenna Pattern

The patterns of A, B, A+B, A-B and normalized difference  $\frac{A-B}{A+B}$  are shown in Figure 15.

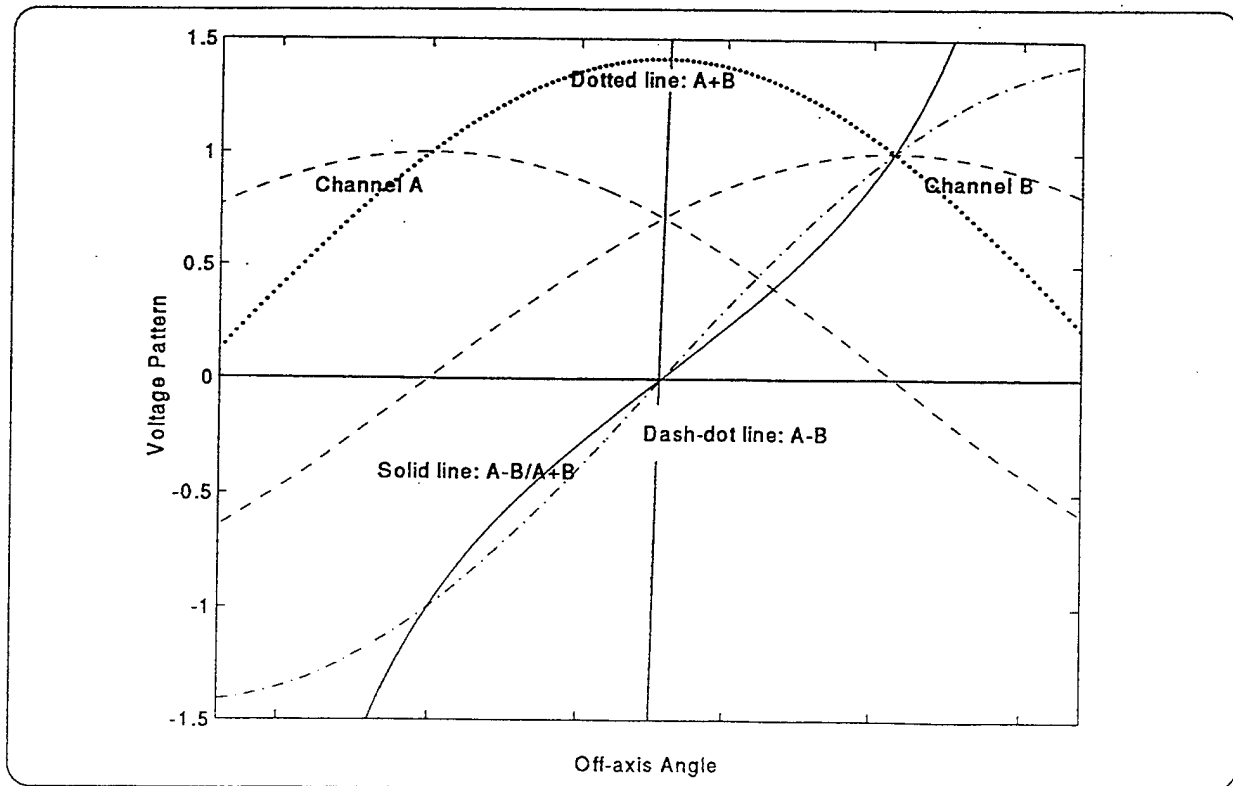

Figure 15. Amplitude-comparison Monopulse Patterns

## V. DISCUSSION

Before discussing the effects of different decoy deployments, the missile-to ship geometry needs to be defined. The geometry can be categorized into two cases, bow/stern attack and beam attack.

In general, a beam attack is preferred by the attacker. In this case, not only does the target ship have a higher RCS, which results in a stronger return signal power, but also the longer physical cross length provides a higher probability of a hit. Oppose to the attacker's favorite beam attack, the defending ship will try to maneuver to reduce its RCS and physical cross section, also reducing the maximum angle that the hardkill systems must cover. This is usually accomplished by heading into the missile's oncoming angle.

To cover both cases, bow/stern and beam attack, the following missile-to-ship angle are chosen to simulate the optimized decoy deployment:

- \* bow attack:  $345^{\circ}, 0^{\circ}, 10^{\circ}, 20^{\circ}$
- \* starboard attack:  $45^{\circ}, 60^{\circ}, 90^{\circ}, 120^{\circ}$
- \* stern attack:  $150^{\circ}, 165^{\circ}, 180^{\circ}, 210^{\circ}$
- \* port attack:  $240^{\circ}, 270^{\circ}, 300^{\circ}, 330^{\circ}$

### A. DECOY DEPLOYMENT ANGLE

The first thing to be discussed is the decoy deployment angle. Decoys can be launched at different angles to protect the ship from the missile attacking angles given above. Table 4 shows the protection envelop provided by different decoy developments against a missile coming from 345 degrees. It is assumed that the missile seeker turn-on distance is 10000 m from the target ship. This is 60 seconds before the missile reaches the target at velocity of 0.9 mach. The decoy deployment distance is set at 150 m from the ship.

$\theta_D$	Miss Dis.(m)	$\theta_D$	Miss Dis.(m)	$\theta_D$	Miss Dis.(m)	$\theta_D$	Miss Dis.(m)
0	174.38	90	78.96	180	244.25	270	339.71
10	152.27	100	87	190	266.36	280	331.66
20	131.91	110	98.76	200	286.74	290	319.89
30	113.88	120	113.88	210	304.77	300	304.77
40	98.76	130	131.9	220	319.89	310	286.74
50	87.01	140	152.27	230	331.66	320	266.36
60	78.96	150	174.38	240	339.71	330	244.25
70	74.88	160	197.55	250	343.79	340	221.08
80	74.88	170	221.08	260	343.79	350	197.55

Table 4. Decoy Deployment Angle versus Miss Distance with a  $345^\circ$  Attack Angle

Figure 16(a) shows a polar plot of the data in Table 4. Figure 16(b) is the same set of data but normalized by the smallest value in the set to clearly illustrate the optimized decoy deployment angle.

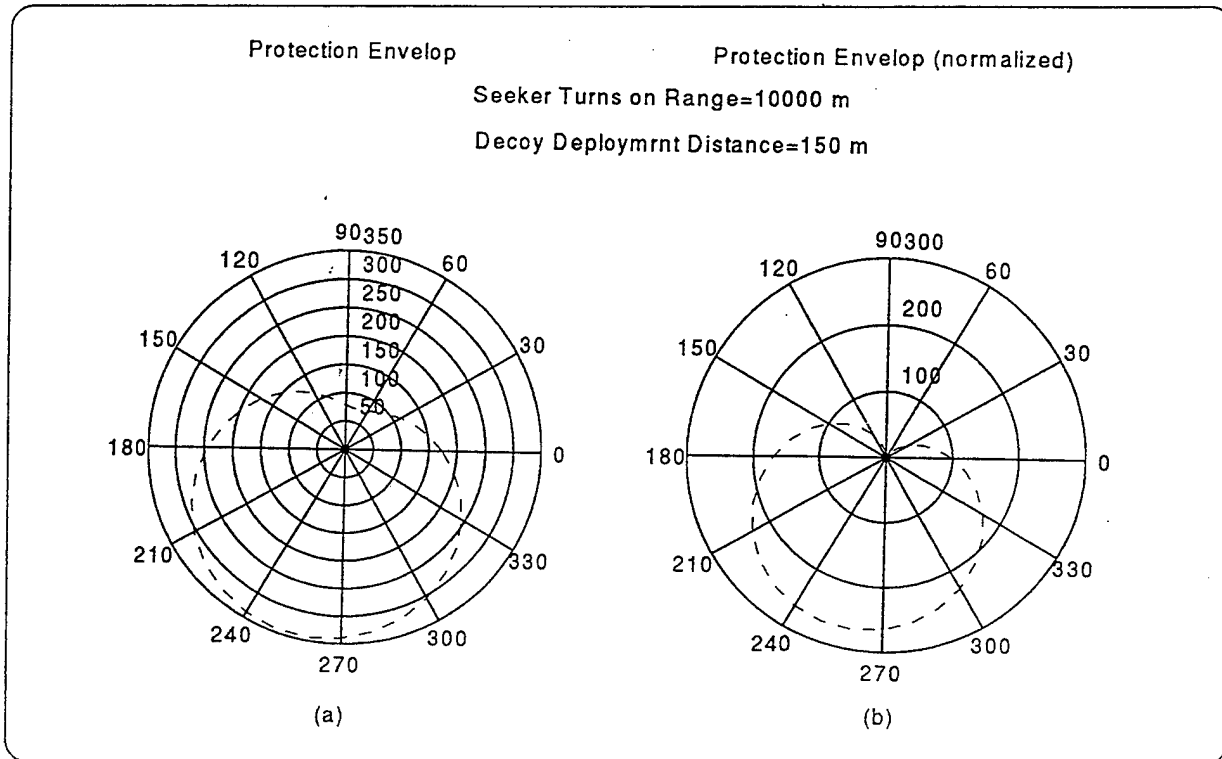

Figure 16. Protection Envelope by Different Decoys for a Missile from  $345^\circ$



From the figure we can see that if the missile comes from  $345^\circ$ , then the best decoy deployment angles are between  $240^\circ$  to  $270^\circ$ . If the tactical situation does not permit this angle of deployment, because the decoy may lure the missile to a sister ship, a wider range from  $210^\circ$  to  $330^\circ$  may still be considered to provide sufficient protection. Similar plots for other attacks (bow, starboard, port and stern attack), are shown in Figure 17 through Figure 20. The best deployment angles are summarized in Table 5.

Missile Attack Angle (degrees)	Best Decoy Angle(degrees)	Better Decoy Angle (degrees)	Good Decoy Angle (degrees)
0	90&270	80~110 & 260~280	60~120 & 240~300
10	100	60~120	30~150
20	110	100~140	50~170
45	135	120~150	75~195
60	150	120~180	90~210
90	180	150~210	120~240
120	210	180~240	150~270
150	240	210~270	180~300
165	255	220~290	195~315
180	90&270	80~110 & 260~280	60~120 & 240~300
210	120	90~150	60~180
240	150	120~180	90~210
270	180	150~210	120~240
300	210	180~240	150~270
330	240	210~270	180~300
345	255	230~280	210~300

Table 5. Optimized Decoy Deployment Angle

From the Figures, we can see a simple fact that the better protection is provided when the distance between decoy and target ship is large as viewed from the missile oncoming angle. Does this imply that longer deployment range provides better protection? This question leads us to the next discussion.

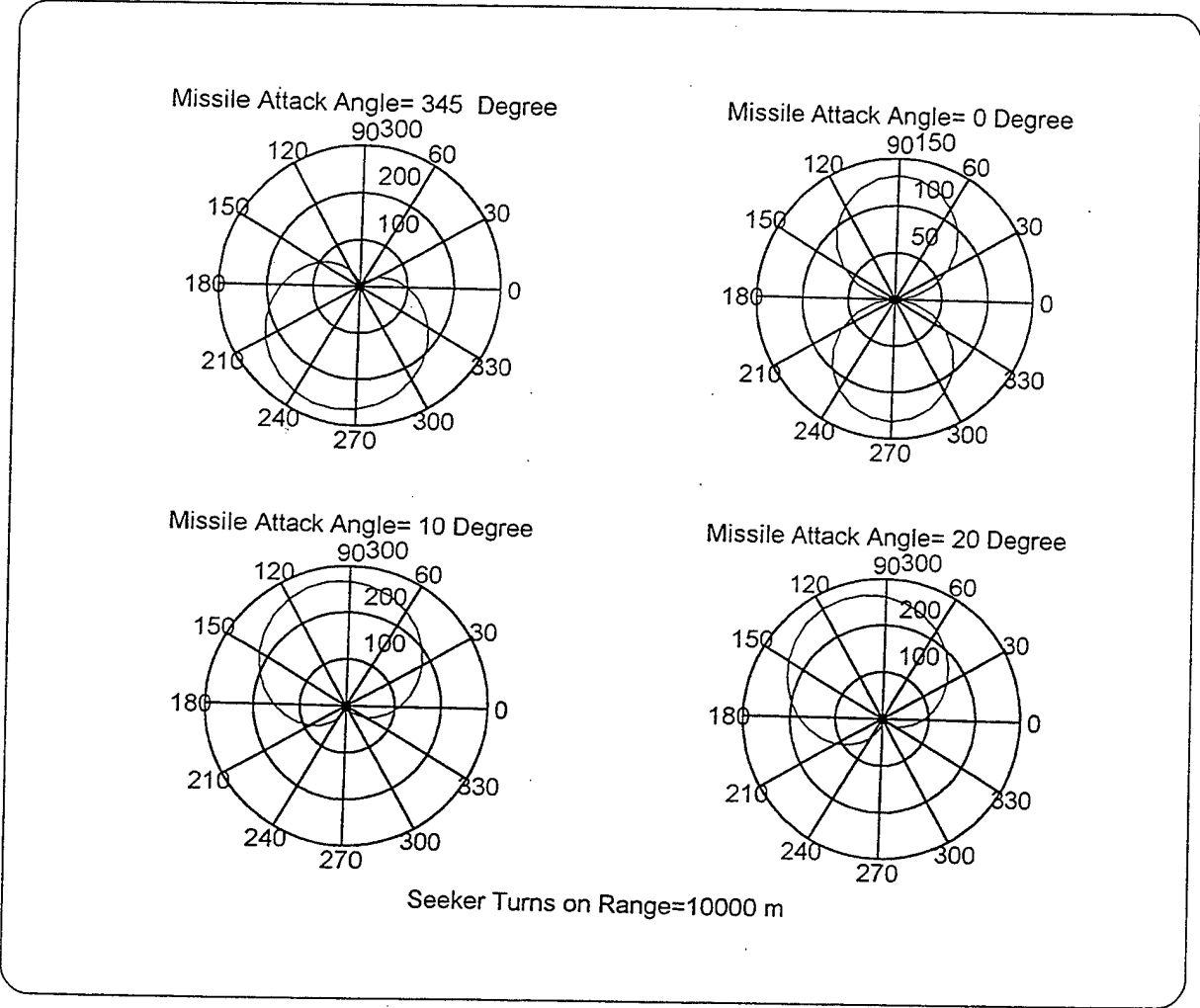

Figure 17. Protection Envelope of Decoy for a Missile from the Bow

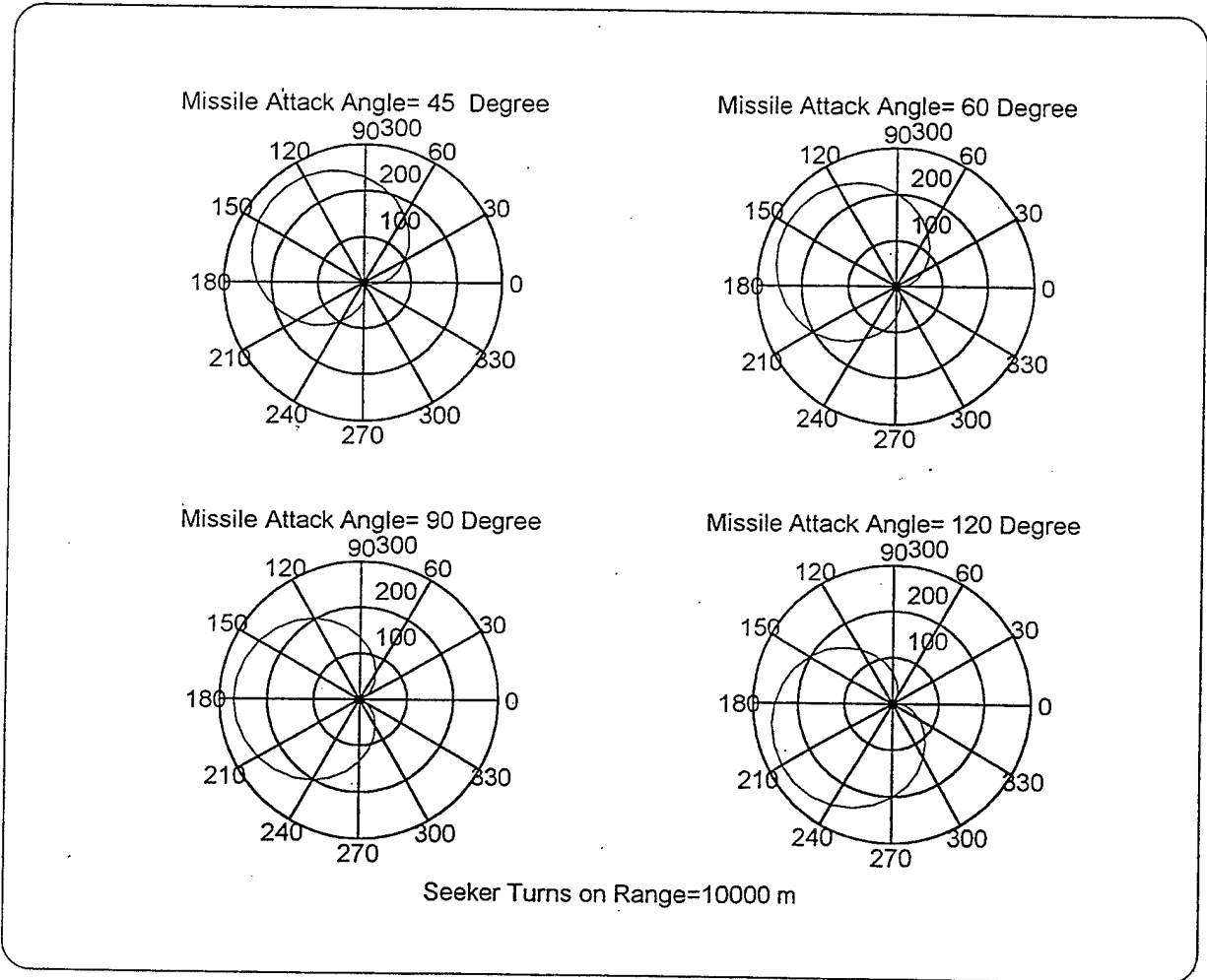

Figure 18 Protection Envelope of Decoy for a Missile from the Starboard Side

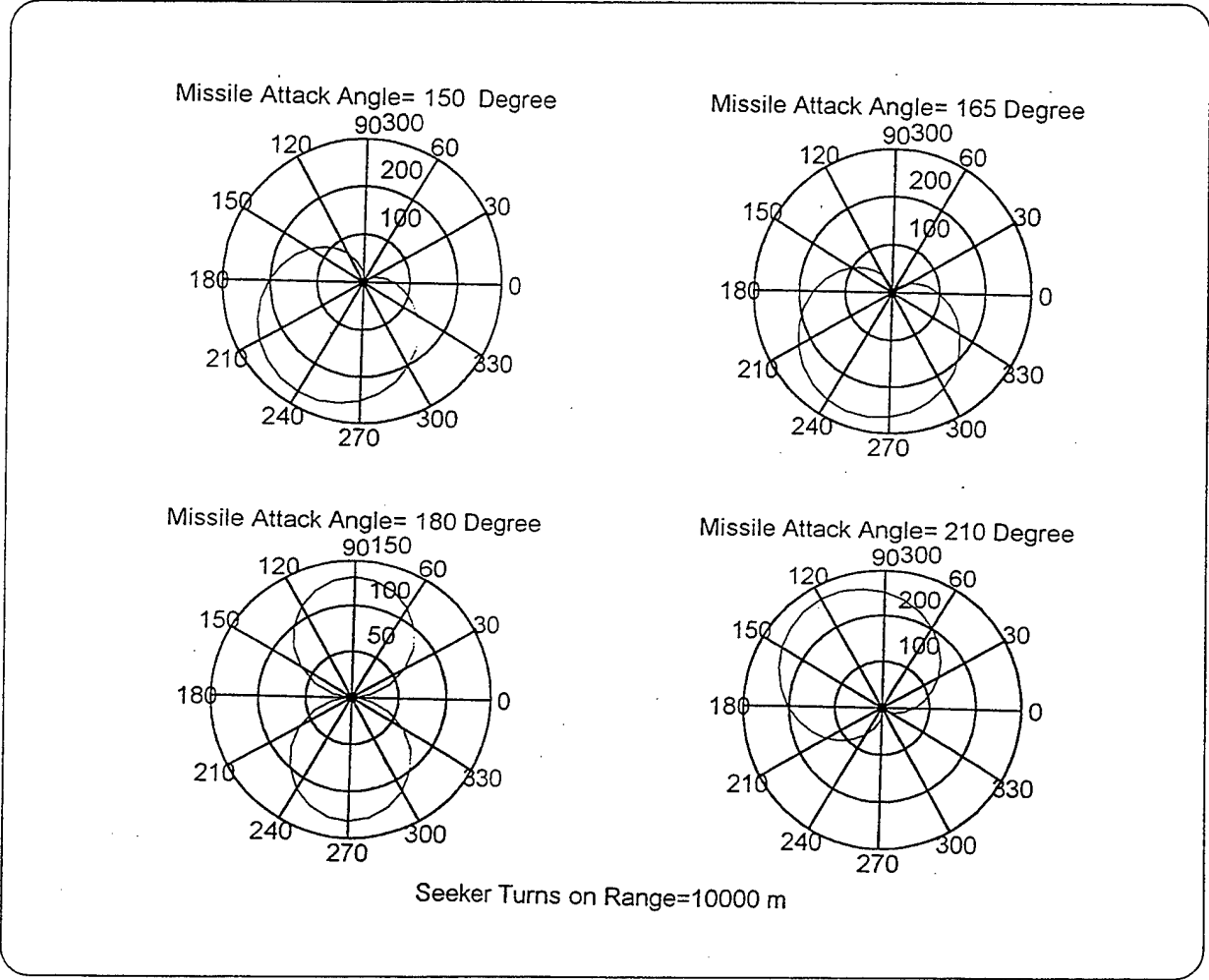

Figure 19 Protection Envelope of Decoy for a Missile from the Stern

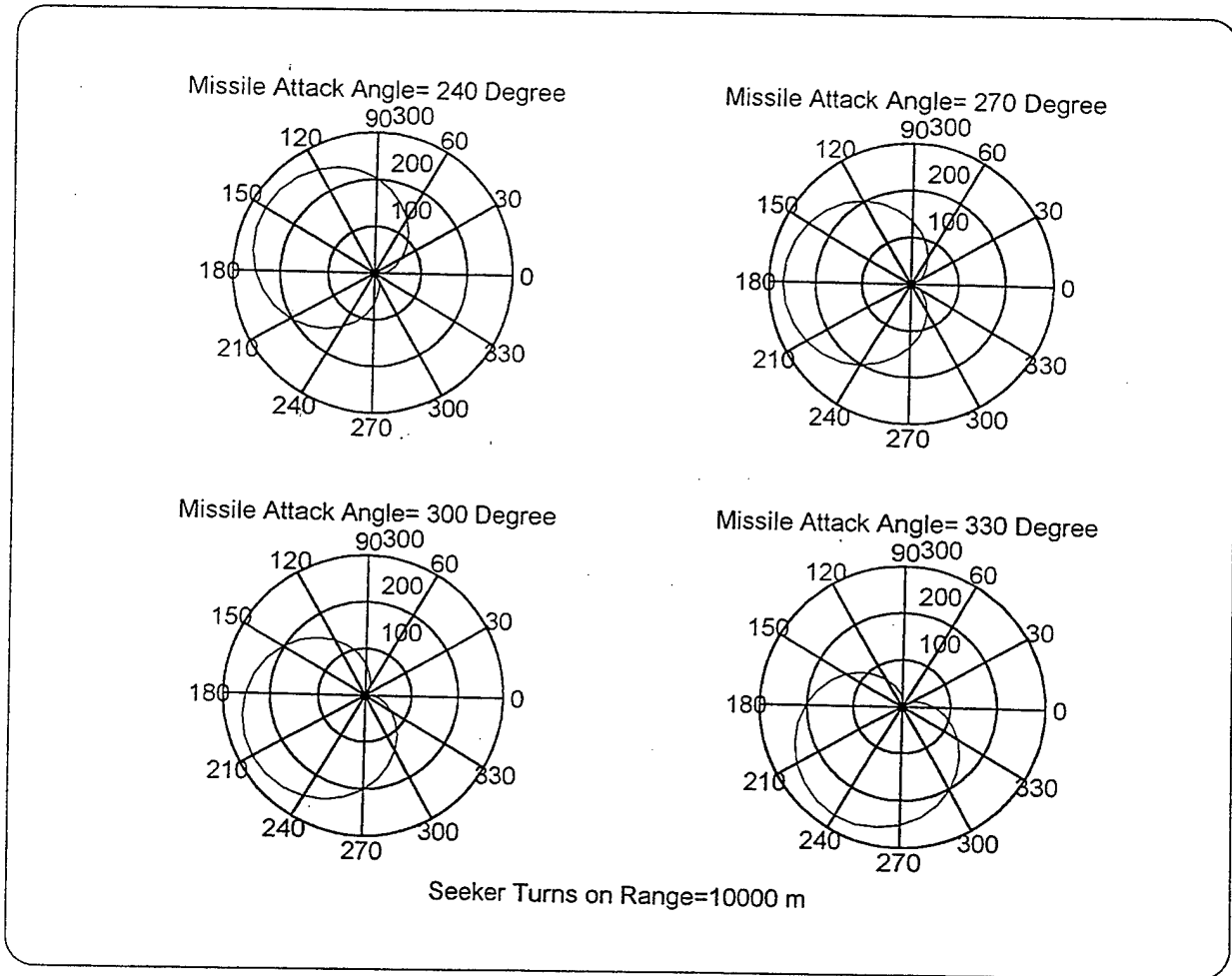

Figure 20. Protection Envelope of Decoy for a Missile from the Port Side

## B. DECOY DEPLOYMENT DISTANCE

To demonstrate the effect of decoy deployment distance, the following simulation settings were chosen:

- Missile Attack Angle =  $0^\circ$
- Missile seeker turn on time = 60 second before reaching the target (10000 m away from the target)
- Decoy deployment angle = from  $0^\circ$  to  $350^\circ$ , 10 degrees increment
- Decoy deployment range = 100 m, 200 m, 300 m.

The results of this simulation are shown in Figure 21. The solid line is the protection envelop provided by the decoy deployed at a distance 100 m from the ship. The dashed line is the protection envelop provided by the decoy deployed at the distance of 200 m. By examining these two protection envelopes, it can be concluded that longer deployment distances provide better protection

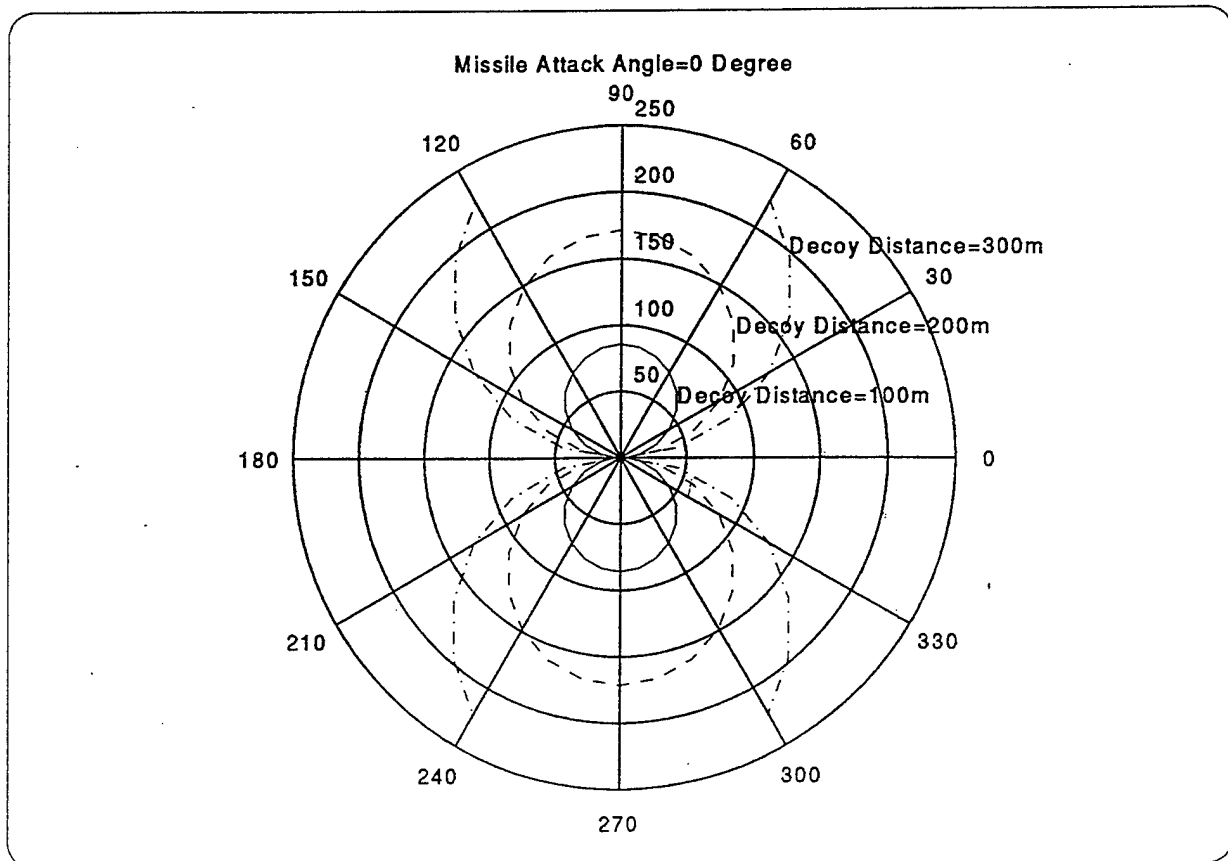

Figure 21. Effect of Different Decoy Deployment Distance (Polar)

However, if we deploy the decoy at 300 m from the ship, the results do not support the conclusion above. The dash-dot line is the protection envelope provided by the 300 m decoy deployment. Within certain angles, for example  $30^\circ$  to  $60^\circ$ ,  $120^\circ$  to  $150^\circ$ ,  $210^\circ$  to  $240^\circ$ , and  $300^\circ$  to  $330^\circ$ , the protection provided is better than that provided by 100 or 200 m decoy deployment. But at the range of  $60^\circ$  to  $120^\circ$  and  $240^\circ$  to  $300^\circ$ , a 300 m decoy deployment distance does not provide any protection. To better describe this, the polar coordinates are changed to the Cartesian coordinates as shown in Figure 22.

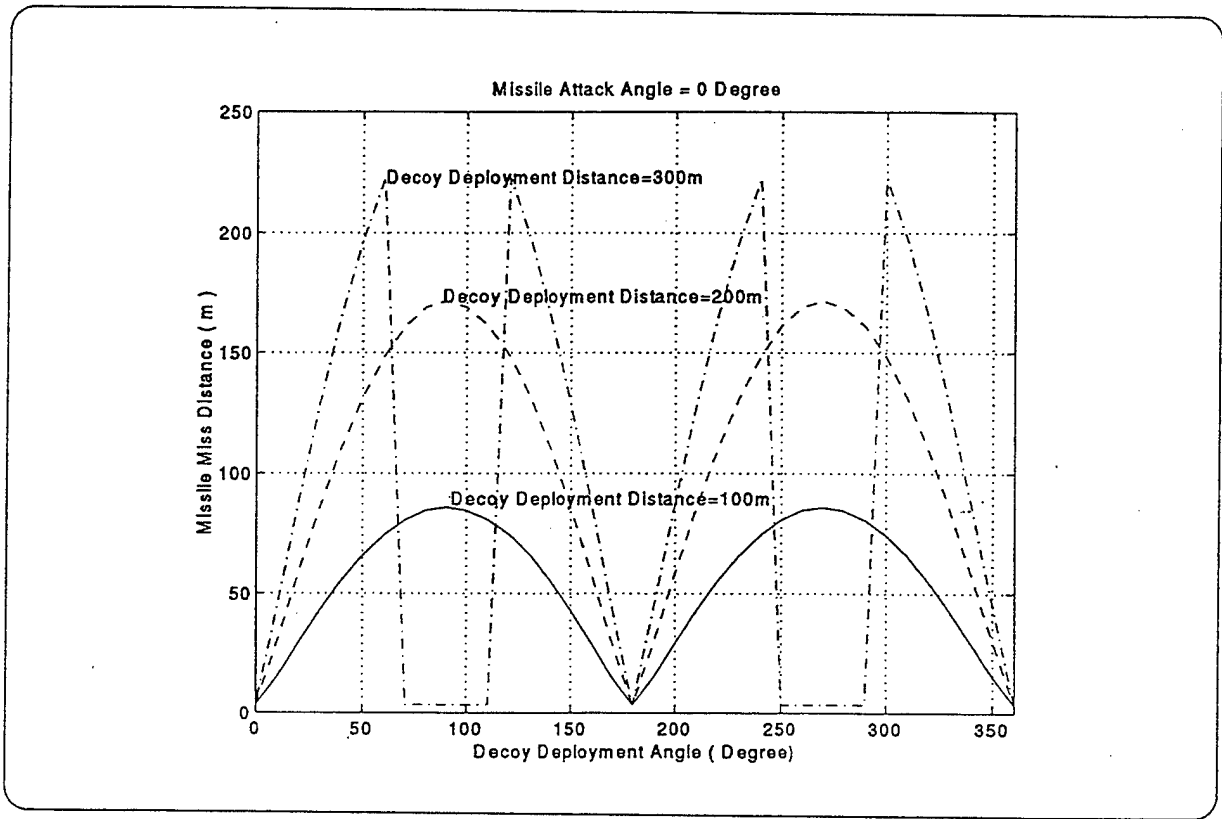

Figure 22 Effect of Different Decoy Deployment Distance (Cartesian)

For a decoy deployed at 300 m , there are two gaps in the protection envelope, from  $60^\circ$  to  $120^\circ$  and from  $240^\circ$  to  $300^\circ$ . The reason of these gaps is because the decoy is out of sight of the missile seeker for that deployment distance and angle. Figure 23 is the illustration of this case,  $\theta_{3dB}$  is the seeker beamwidth,  $R_S$  is the missile distance when the seeker turns on,  $L_R$  is the length of the seeker resolution cell. Then  $L_R$  is given by:

$$L_R = R_S \cdot \tan(\theta_{3dB}). \tag{18}$$

If the decoy is deployed outside this range, the seeker is not affected, and the ship remains the only target source for the missile seeker.

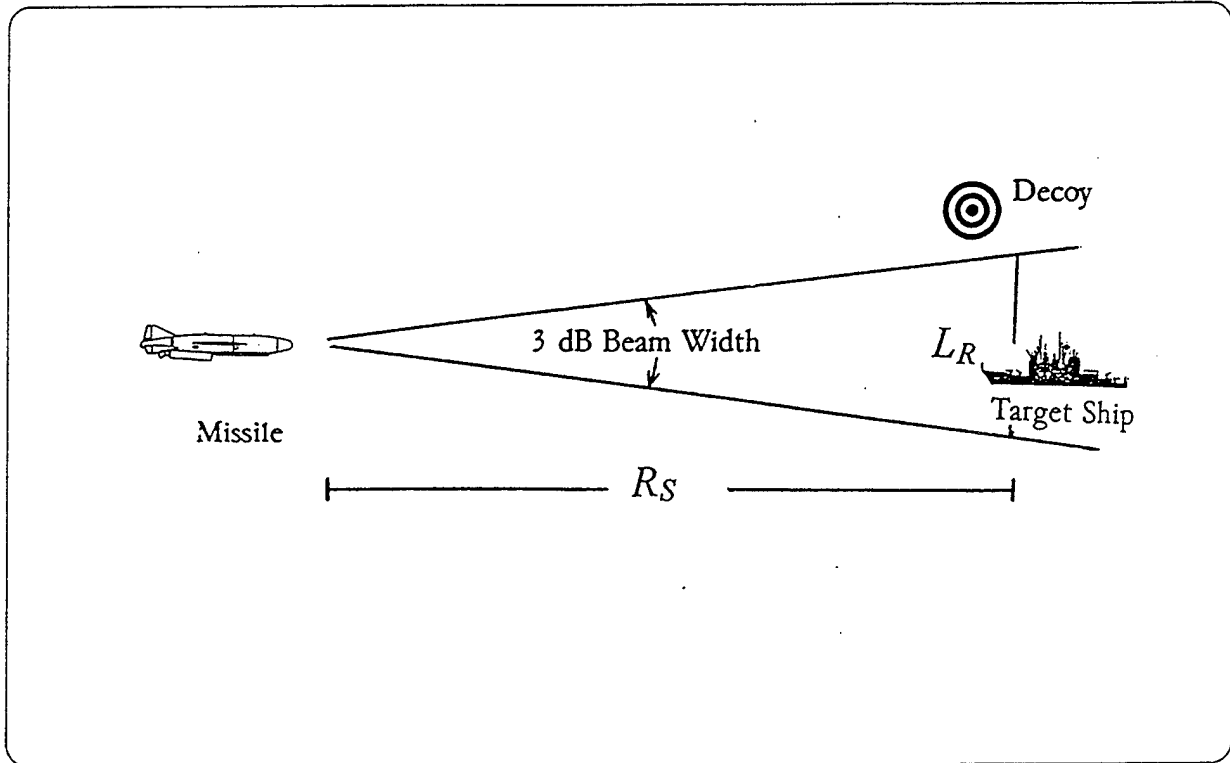

Figure 23. Seeker's Resolution Cell

To ensure the initial decoy deployment can be seen by the seeker, a simple calculation can be done as follows:

$$D_D < \tan(\theta_{3dB}) \cdot (R_S - (S_M \cdot (T_O + T_D))) \cdot \frac{1}{2 \sin(\theta_D)} \quad (19)$$

where

$D_D$  = Decoy Deployment Distance

$S_M$  = Speed of the Missile

$T_O$  = Operation Delay Time

$T_D$  = Decoy Delay Time

and other terms are defined as in Chapter IV.

In a real operation, when the ESM system detects the presence of the missile seeker, EW personnel or computers may determine what kind of missile is approaching by comparing the intercepted signal parameters with a databank. This may supply the speed of the missile and



beamwidth of the seeker. But ESM systems cannot determine the range to the missile at the time of seeker turns on. This must be done by the radar. This is why it is very important for EW and radar personnel to exchange information. If the missile cannot be seen by the radar because of its sea skimming feature, a conservative seeker turn on range should be used to accomplish the above computation. There are two other factors taken into account in Equation 19, which are operation delay time  $T_O$  and decoy delay time  $T_D$ . When the seeker signals are intercepted by the ESM system, it takes some time for the operator or computer to recognize the threat, though the later one is usually very short. After the threat has been verified by the EW operator, he reports the information either to the Combat Information Center (CIC) or to the bridge. An authorized person in CIC or on the bridge then makes his decision to launch the decoy. The total time spent up to this point is the operation delay time. After the decoy has been launched, it requires time to move to the designated location and be ready to receive and transmit RF signals. This time is the decoy delay time. While the defending ship and decoy are performing these tasks, the missile is approaching and the resolution cell becomes smaller.

In conclusion, the longer the deployment distance the better the protection. This is true only if the decoy is in the resolution cell of the seeker. If there is insufficient information to determine the best deployed distance, a better way is for the ship to deploy the decoy at a shorter distance to ensure the seeker sees the decoy. Then the ship should increase its speed or change course to separate the ship and decoy and increase the distance as much as possible.

### **C. DECOY GAIN AND POWER REQUIREMENT**

As discussed in Chapter IV, the decoy power received by the seeker must be stronger than the target ship echo to pull the center-of-gravity of the two target sources closer to the decoy. When the two targets can be resolved, the seeker will track the decoy, instead of the target ship. The decoy must have adequate gain when it acts as a constant gain system, and enough power when it is saturated and changes to a constant power system to ensure that the seeker tracks the decoy.

#### **1. Decoy Gain Requirement**

The decoy gain required for establishing a certain jam-to-signal ratio can be derived from Equation 13 as

$$G_D = \frac{4\pi\sigma L_P^2 R_D^4}{\lambda^2 R_S^4} \cdot \left(\frac{J}{S}\right). \quad (20)$$

For  $R_D = R_S$ ,  $L_P = 3\text{dB}$  and  $\lambda = 9250\text{ MHz}$ , the required decoy power is then given by

$$G_D = 46.76 + \sigma + \left(\frac{J}{S}\right). \quad (21)$$

Note that the target the decoy wants to protect is assumed in this thesis to be a frigate. The RCS of a frigate is as high as  $1000\text{ m}^2$ . This means, the required decoy gain must be as high as 83 to 86 dB to achieve 7 to 10 dB jam-to-signal ratio.

## 2. Decoy Power Requirement

As stated in Chapter VI, the decoy saturates when maximum power output is demanded, Figure 13 shows that the saturation point occurs at a range of 3700 m and burn-through range of 1600 m, when the maximum decoy output power is 1 kw. If the decoy maximum power is increased to 2 kw, the saturation range becomes 2600 m and the burn-through range is decreased to 1100 m as shown in Figure 24. A question that might be asked here is what do those numbers mean for the effectiveness of the decoy? We know the target return echo will be stronger than the decoy power at the radar receiver after burn-through occurs. If at that moment, both target sources are still in the seeker's resolution cell, the seeker will no longer see the decoy as the most attractive target. Instead, it will lock back onto the ship. From Equation 19, we can clearly see that if the burn-through happens at a shorter range, the seeker resolution cell will be narrower thus reducing the probability of two target sources being seen by the seeker at that point. So a higher maximum power is desired to prevent an early burn-through.

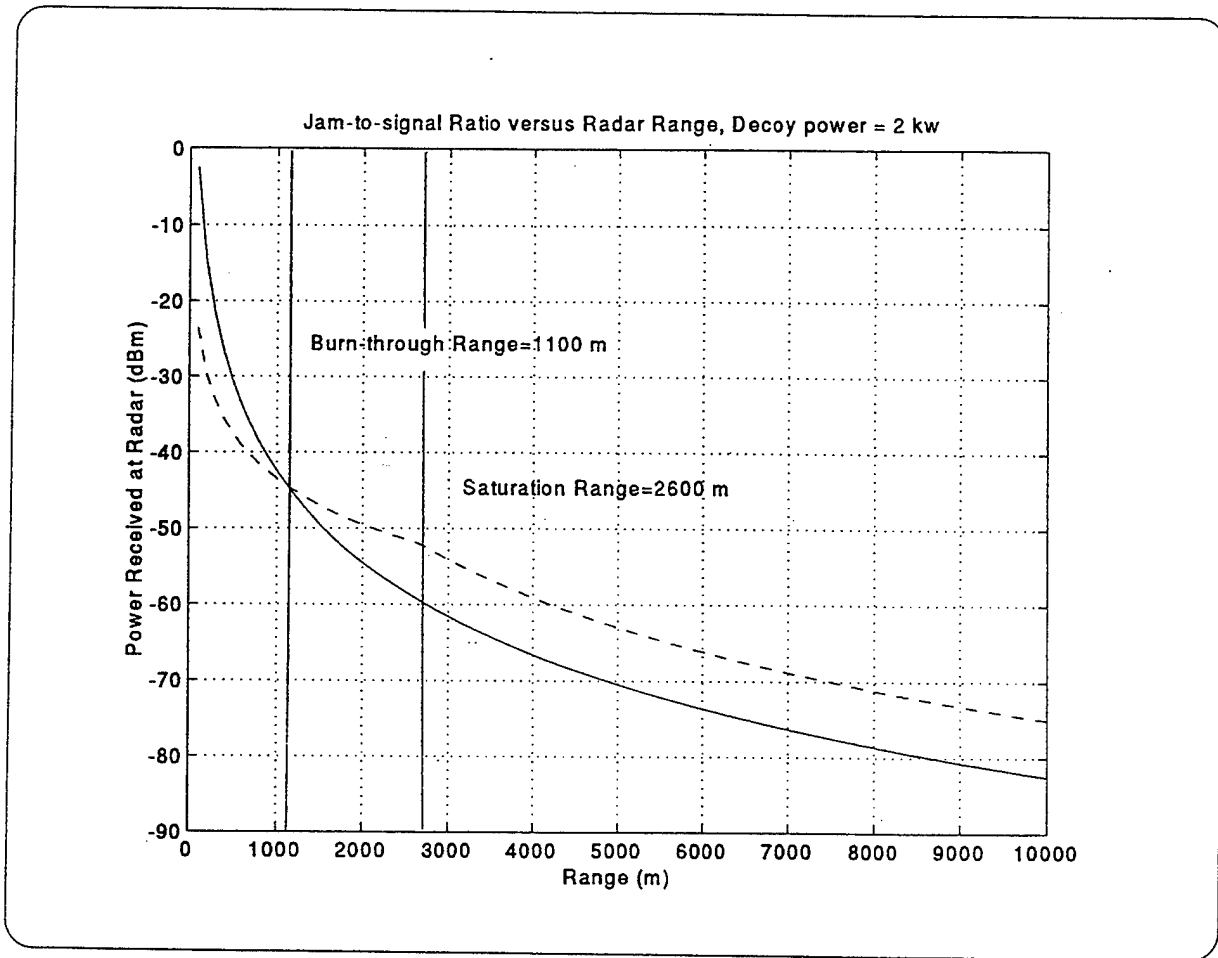

Figure 24. Decoy Power versus Ship Echo at Seeker's Receiver



## VI. CONCLUSIONS

This thesis has investigated three decoy deployment parameters. They are the deployment angle, deployment distance, and the required gain/power. The result has shown that for the deployment angle, better protection is provided when the distance between the decoy and the target ship is large as viewed from the oncoming missile angle. This not only keeps the ship at a safe distance when the missile hits the decoy and explodes, but also prevents the possibility of the seeker jumping back and locking-on the ship. To achieve this goal, the best decoy deployment angle has been obtained for each missile attacking angle. Also, because the decoy launchers are very simple and do not have very good accuracy, these deployment angles have been established as ranges of angles rather than an exact angle. Within these ranges, the decoy deployment can still provide protection for the ship.

In investigating the best deployment distance, we found a longer deployment distance is preferred as long as the decoy is in the seeker's resolution cell. The attacker will try to reduce the resolution cell size by delaying seeker turn-on to reduce the probability of being jammed. While the defender minimizes any delay in deployment to ensure that the decoy can be put far away from the ship and still within the resolution cell.

The gain and power are critical factors in so far as decoy effectiveness is concerned. To protect a ship from missile attack, a high decoy gain and power are needed because the ship's RCS is large and results in a strong echo power that is difficult for the decoy jamming signal to overcome. If the gain and power are limited by the nature of the decoy components, the defending ship must maneuver to a course so that the ship's RCS as viewed by the seeker is small.



## LIST OF REFERENCES

1. Sharpe, Richard, *Jane's Fighting Ships 1995~1996*, Jane's Information Group Inc., 1996.
2. Skolnik, Merrill I., *Radar Handbook, 2nd ed.*, McGraw-Hill Inc., 1995.
3. Chrzanowski, Edward J., *Active Radar Electronic Countermeasures*, Artech House Inc., 1990.
4. Schleher, D. Curtis, *Introduction to Electronic Warfare*, Artech House Inc., 1986.
5. *The World's Missile Systems*, General Dynamics Pomona Division, 1988.





## INITIAL DISTRIBUTION LIST

1. Defense Technical Information Center 2  
8725 John J. Kingman Rd., STE 0944  
Ft. Belvoir, VA 22060-6218
2. Dudley Knox Library 2  
Naval Postgraduate School  
411 Dyer Rd.  
Monterey, CA 93943-5101
3. Frederic H. Levien, Code EW 1  
Electronic Warfare Academic Group  
Naval Postgraduate School  
Monterey, CA 93943
4. D.C. Schleher, Code EW/Sc 2  
Department of Electrical and Computer Engineering  
Naval Postgraduate School  
Monterey, CA 93943-5101
5. David Jenn, Code EC/Jn 1  
Department of Electrical and Computer Engineering  
Naval Postgraduate School  
Monterey, CA 93943-5101
6. Tun-Hou, Tan 2  
LCDR, Taiwan, R.O.C. Navy  
#17, Ln. 415, Nan-Tzu Dis., Chiu-Chang St., Koahsiung  
Taiwan, R.O.C.